

DESCRIPTION

The Echotel® 961/962 series utilizes pulse signal technology to detect high or low level alarm(s) in a broad range of viscous to light liquids. Pulsed signal technology provides superior performance in applications suffering from foam, aeration, heavy turbulence and suspended solids.

The Echotel® 961 has a tip sensitive setpoint and is ideally used as high or low level alarm.

The Echotel® 962 offers 2 setpoints on the same transducer, a tip sensitive setpoint and a second setpoint via a flow-through upper gap. The unit is used for level alarm or to control a pump in an auto fill/empty mode.

The Echotel® 961/962 is equipped with advanced diagnostics that continuously check the transducer and electronics. The diagnostics also alarm for electrical noise interference from external sources.

FEATURES

- No calibration
- 2 wire loop powered with mA output or AC/DC line powered with integrated relay(s)
- Continuous selftest with selectable error output
- LED identification for:
 - process alarm
 - error of transducer, electronics or electrical noise interference
 - wet/dry status of transducer
- Push buttons for manual testing of alarm and error signals
- Adjustable time delay up to 45 s
- Metal and plastic transducers
- Suited for SIL 1 and SIL 2 loops (full FMEDA report available)



APPLICATIONS

- LIQUIDS: Any liquid with a viscosity < 10.000 cP.
- VESSELS: Any mounting position.
- PROCESS CONDITIONS: Unaffected by
 - shifting dielectric, density, or pH
 - presence of foam, turbulence, visible vapours
 - fast drain/fill rates
 - transducer coating and air bubbles
 - vacuum conditions.

Loop or line powered



AGENCY APPROVALS

Agency	Approval
ATEX ①	II 1G EEx ia II C T5, intrinsically safe II 1/2 G EEx d II C T6, flameproof enclosure
TÜV	WHG §19
AIB	VLAREM II - 5.17.7
FM/CSA ②	
Russian Authorisation Standards ②	
Other approvals are available, consult factory for more details	

① Only for metal transducers.

② Consult factory for proper model numbers and classifications

PRINCIPLE OF OPERATION

The Echotel® 961/962 operates on a two crystal pulsed or "transmit-receive" principle which applies a high frequency electronic burst to the transmit crystal. The signal is then converted into ultrasonic energy and transmitted across the sensing gap towards the receiver crystal. When there is air

in the gap, the high frequency ultrasonic energy will be attenuated, thereby not allowing the energy to be received. When there is liquid in the gap, the ultrasonic energy will propagate across the gap and the current shift or relay output will indicate a reception of the signal.

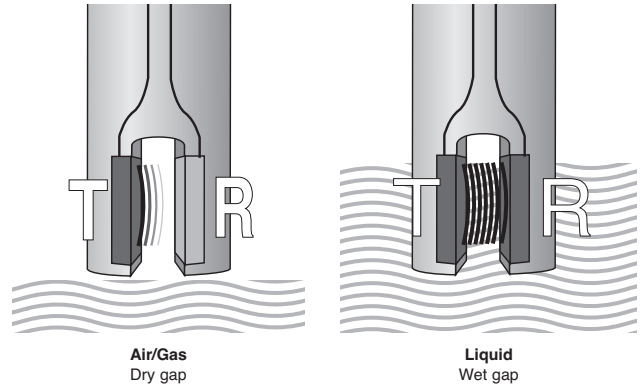
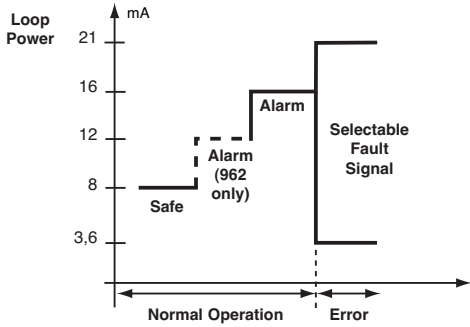

MOUNTING

Ambient temperature: -40°C (-40°F) to +70°C (+160°F)

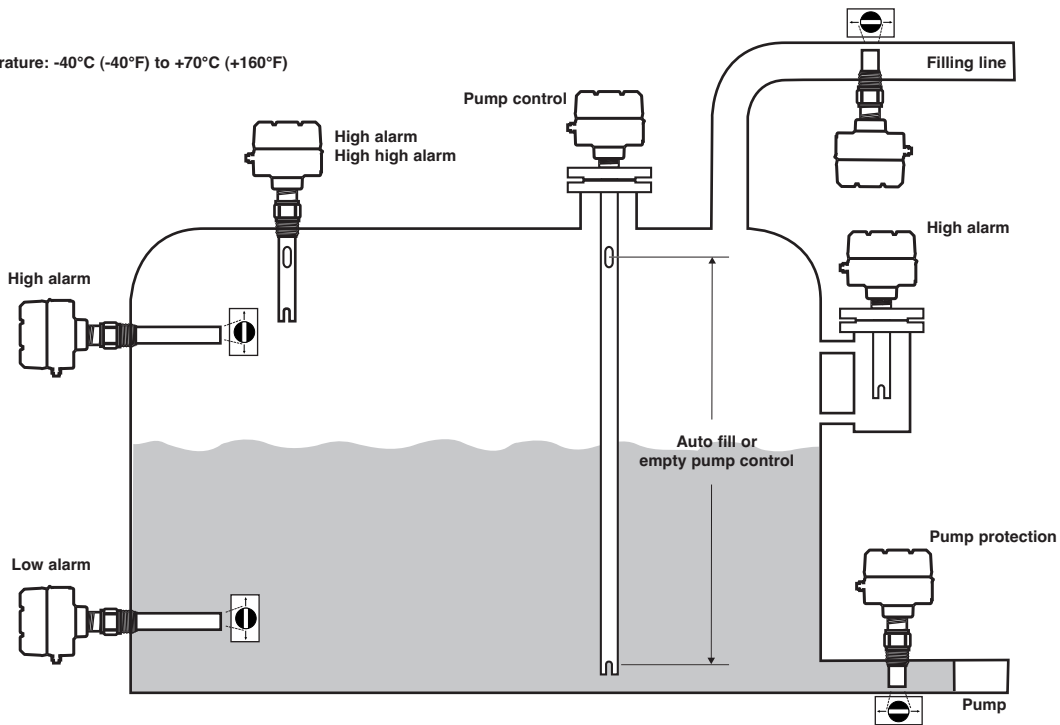

APPLICATIONS

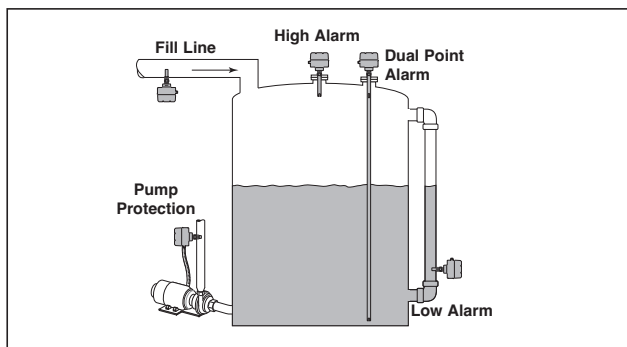

High/Low Level Alarm

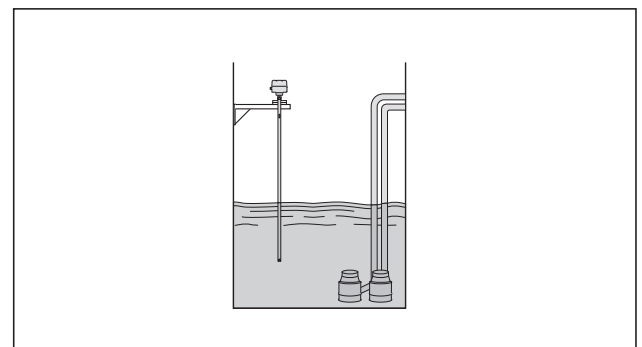

Pump Control

ELECTRONICS SPECIFICATIONS

Description		Specification
Input Voltage	mA - version	2 wire loop powered, 11 - 35 V DC
	Relay - version	102 - 265 V AC 50/60 Hz or 18 - 32 V DC
Power Consumption		< 3 Watt (relay version) – < 1 Watt (mA version)
Output	mA - version	961 : 8 mA (safe), 16 mA (alarm) ± 1 mA 962 : 8 mA (safe), 12 mA (lower gap alarm), 16 mA (upper gap alarm) ± 1 mA 961/962 : ≤ 3,6 or ≥ 22 mA error signal
	Relay - version	961 : one 5 A DPDT relay 962 : two 5 A SPDT relays 961/962 : one 5 A SPDT malfunction relay
Time delay		0,5 to 45 s adjustable (in addition to transducer response time)
Indication		LED's for process alarm status, malfunction (error of transducer, electronics or electrical noise interference) and wet/dry status of transducer (961 with relay only)
Selftest	Automatic	Continuously verifies electronics, transducer and noise interference
	Manual	Via pushbutton for checking alarm output(s) and error output/function
Housing material		IP66, cast aluminium or cast stainless steel
Approvals		ATEX II 1 G EEx ia IIC T5, intrinsically safe (current shift units with metal transducers) ATEX II 1/2 G EEx d IIC T6, flameproof enclosure (units with metal transducers) Overfill prevention TÜV - WHG § 19 / VLAREM II 5.17.7 Other approvals are available, consult factory for more details
SIL (Safety Integrity Level)		Functional safety to SIL 2 in accordance to IEC 61508 – SFF > 90 % Full FMEDA report and declaration sheets available at request
Electrical data		Ui = 28,4 V, li = 94 mA, Pi = 0,67 W (mA version)
Equivalent data		Ci = 10,4 nF (961) / Ci = 60 nF (962), Li = 400 µH (mA version)
Shock/Vibration		ANSI/ISA-S71.03 Class SA1 (shock), ANSI/ISA-S71.03 Class VC2 (vibration)
Net weight		Alu: 1 kg (2.2 lbs) – electronics only SST: 2,5 kg (5.5 lbs) – electronics only

PERFORMANCE

Description	Specification
Response time	0,5 s typical
Repeatability	± 2 mm (0.078")
Ambient Temperature	-40 °C to +70 °C (-40 °F to +160 °F)
Humidity	0-99 %, non-condensing
Electromagnetic Compatibility	Meets CE requirements (EN 61326: 1997 + A1 + A2) and NAMUR NE 21

TRANSDUCER SPECIFICATIONS

Description	Plastic transducers	Metal transducers
Material	CPVC Kynar® (PVDF)	316/316L SST (1.4401/1.4404) Hastelloy® C (2.4819) Monel® (2.4360)
Mounting	Threaded (NPT/BSP) – Flanged (ANSI - EN (DIN))	
Actuation length	From 5 cm up to 330 cm (2" up to 130")	From 3 cm up to 330 cm (1.2" up to 130")
Process temp. (consult temp/press. graphs)	-40 °C to +120 °C (-40 °F to +250 °F) – PVDF -40 °C to +80 °C (-40 °F to +180 °F) – CPVC	-40 °C to +165 °C (-40 °F to +325 °F) – standard -80 °C to +120 °C (-110 °F to +220 °F) – low temperature version in 316/316L SST
Max pressure (consult temp/press. graphs)	13,8 bar @ +40 °C (200 psi @ +100 °F) for NPT threaded units	82,8 bar (1200 psi) for Monel transducers Consult temp/press. graphs for other materials
	Flanged models are downrated to the design pressure of the selected flange	
Max viscosity	10.000 cP	

ELECTRONICS



Loop powered 961



Line powered 961

FUNCTIONS

Adjustable time delay:

The Echotel® 961/962 provides a fast response time of typically < 1s. In applications with turbulent or boiling surfaces, this may lead to scattering of the output. For these applications, the user can adjust via a potentiometer a time delay from 1 to 45 s and avoid scatter of the output.

Pushbuttons for manual check: The alarm output and the error signal of the Echotel® 961/962 can be manually checked via pushbuttons. For loop powered units, the loop test pushbutton will sequentially check the shift of loop current. For relay operated units, the level test pushbutton will make the relay change from energized to de-energized status or vice versa. Pressing the fault/malfunction pushbutton stops all transmit pulses, which simulates an electronics failure, and tests the selected output signal.

LED identification:

Alarm LEDs report alarm status. For 962 models, the alarm status per gap is reported. A separate LED on the 961 model (with relay output), reports independently from the alarm status, whether the gap is immersed or not.

Fault LED reports a malfunction of the unit. The blinking sequence of the LED identifies the failure (electronics, transducer or electrical noise interference). Malfunction LED (only for units with relay) confirms that the malfunction relay is energized in normal operation

Pump Control (only 962 model with relays):

The model 962 with relays can be set for pump control or level alarm. By selecting pump control (PC), the unit will latch its 2 SPDT relays and provide automatic fill or drain function between its 2 setpoints. In level alarm mode (LC), the unit will detect either high and high-high or low and low-low level alarm.

Selectable error signal:

The error signal of loop powered units (961/962) can be set for either 3,6 or 22 mA. The separate malfunction relay of the 961 can be set for independent or joint operation with the alarm relay. The 962 with relays will always report a malfunction via the alarm relay.

ELECTRICAL WIRING

Loop powered

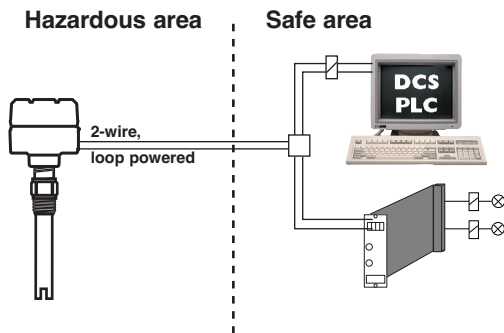

Line powered

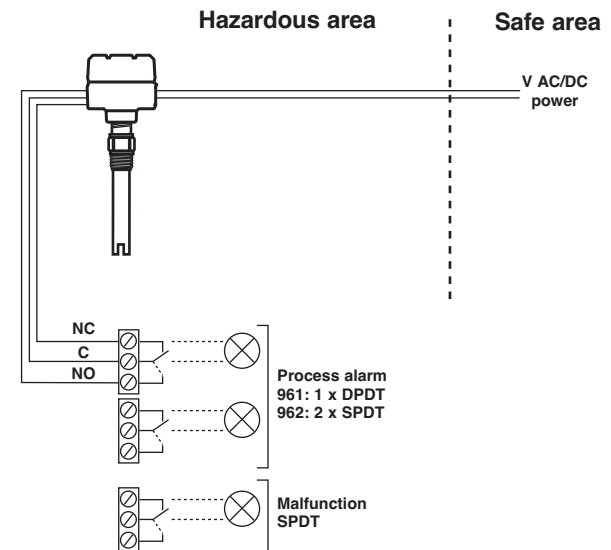

EXPEDITE SHIP PLAN (ESP)

Several models are available for quick shipment, within max. 4 weeks after factory receipt of purchase order, through the Expedite Ship Plan (ESP).

Models covered by ESP service are conveniently grey coded in the selection data charts.

To take advantage of ESP, simply match the colour grey model number codes (standard dimensions apply).

ESP service may not apply to orders of ten units or more. Contact your local representative for lead times on larger volume orders, as well as other products and options.

ECHOTEL® 961 / 962 – ELECTRONICS

Selection data

A complete measuring system consists of:

1. Echotel® electronics
2. Echotel® transducer

1. Order code for Echotel® electronics

BASIC MODEL NUMBER

9 6 1	Echotel® 961 electronics for single setpoint 9M1 transducers
9 6 2	Echotel® 962 electronics for dual setpoint 9M2 transducers

INPUT POWER

5 0 A	24 V DC 2-wire loop powered electronics with current shift output
2 D A	18 - 32 V DC line powered electronics with 5 A gold flash relay(s) output
7 D A	102 - 265 V AC line powered electronics with 5 A gold flash relay(s) output

ACCESSORIES

0	Blind housing cover
1	Housing cover with glass window (for aluminium housings only)

MOUNTING

0	Integral mount electronics
---	----------------------------

APPROVALS

Units with current shift output (digit 5 = 0)

A	ATEX II 1 G EEx ia IIC T5, intrinsically safe
C	ATEX II 1/2 G EEx d IIC T6, flameproof enclosure
1	Weatherproof

Units with relay output (digit 5 = D)

C	ATEX II 1/2 G EEx d IIC T6, flameproof enclosure
3	Weatherproof

HOUSING / CABLE ENTRY

1	Cast aluminium housing with M20 x 1,5 cable entry (2 entries – one plugged)
0	Cast aluminium housing with 3/4" NPT cable entry (2 entries – one plugged)
3	Cast stainless steel with M20 x 1,5 cable entry (2 entries – one plugged)
2	Cast stainless steel with 3/4" NPT cable entry (2 entries – one plugged)

9	6			A		0		
---	---	--	--	---	--	---	--	--

complete order code for Echotel® electronics

→ X = product with a specific customer requirement

DIMENSIONS IN mm (inches)

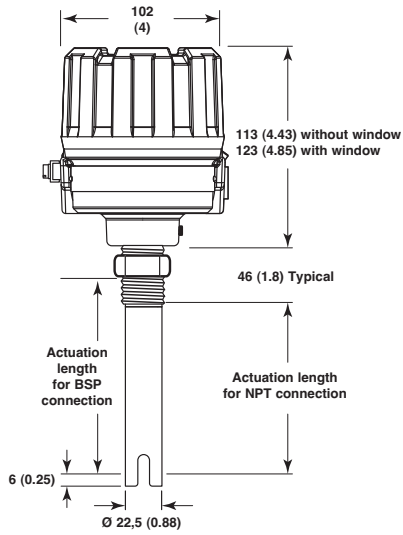

961 - Threaded connection

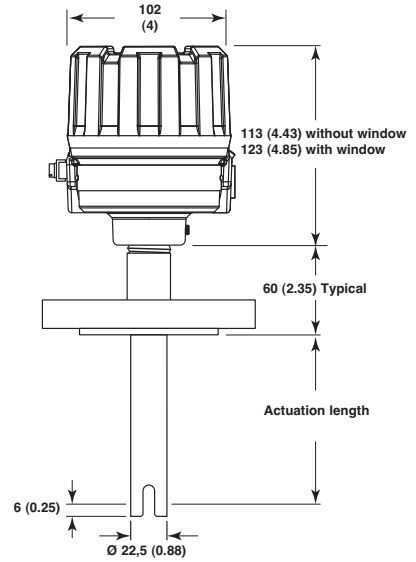

961 - Flanged connection

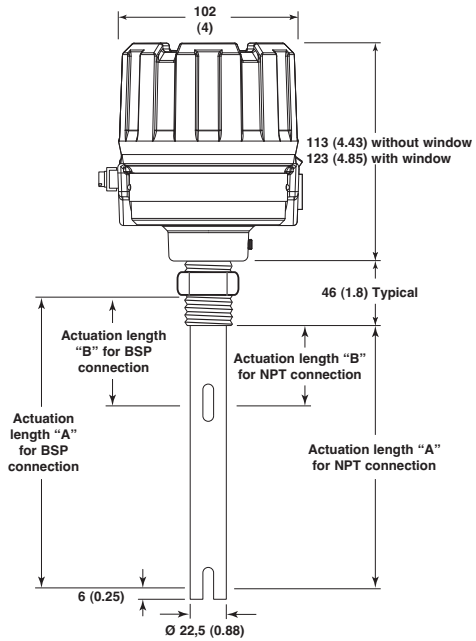

962 - Threaded connection

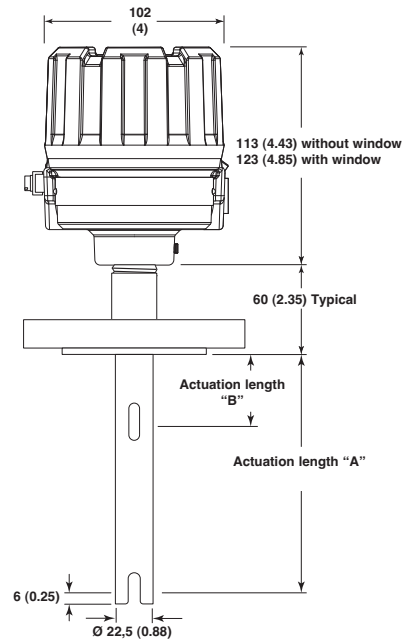

962 - Flanged connection

ECHOTEL® 961/962 transducer

2. Order code for Echotel® transducer

BASIC MODEL NUMBER

9 M 1	Echotel® 961 transducer with single setpoint
9 M 2	Echotel® 962 transducer with dual setpoints

TRANSDUCER MATERIALS (use only metal transducers for hazardous area)

A	316/316L (1.4401/1.4404) stainless steel
B	Hastelloy® C (2.4819) – only available with 9M1
C	Monel® (2.4360) – only available with 9M1
P	CPVC
R	Kynar® (PVDF) – only available with 9M1

PROCESS CONNECTION

Threaded (plastic transducers are only available with 3/4" NPT connection)

1 1	3/4" NPT
2 1	1" NPT
2 2	1" BSP (G 1")

ANSI Flanges for metal transducers

2 3	1"	150 lbs	ANSI RF
2 4	1"	300 lbs	ANSI RF
2 5	1"	600 lbs	ANSI RF
3 3	1 1/2"	150 lbs	ANSI RF
3 4	1 1/2"	300 lbs	ANSI RF
3 5	1 1/2"	600 lbs	ANSI RF
4 3	2"	150 lbs	ANSI RF
4 4	2"	300 lbs	ANSI RF
4 5	2"	600 lbs	ANSI RF

EN (DIN) Flanges for metal transducers

B B	DN 25	PN 16/25/40	EN 1092-1 Type A
B C	DN 25	PN 63/100	EN 1092-1 Type B2
C B	DN 40	PN 16/25/40	EN 1092-1 Type A
C C	DN 40	PN 63/100	EN 1092-1 Type B2
D A	DN 50	PN 16	EN 1092-1 Type A
D B	DN 50	PN 25/40	EN 1092-1 Type A
D D	DN 50	PN 63	EN 1092-1 Type B2
D E	DN 50	PN 100	EN 1092-1 Type B2

ANSI Flanges for plastic transducers^①

2 3	1"	150 lbs	ANSI RF ^②
3 3	1 1/2"	150 lbs	ANSI RF ^②
4 3	2"	150 lbs	ANSI RF ^②

EN (DIN) Flanges for plastic transducers^①

B A	DN 25	PN 16	EN 1092-1 Type A
C A	DN 40	PN 16	EN 1092-1 Type A
D A	DN 50	PN 16	EN 1092-1 Type A

- ① CPVC flanges for CPVC transducers, Kynar® clad SST flanges for Kynar® transducers
 ② FF (flat face) flanges for CPVC transducers

SENSOR TYPE

A	Standard sensor: min -40 °C / max +165 °C (-40 °F / +325 °F)
C	Low temperature sensor: min -80 °C / max +120 °C (-110 °F / +250 °F) – only available with 9M1-A

ACTUATION LENGTH – specify per cm (0.39") increment
 Total insertion length = actuation length + 6 mm (0.25")

9M1 transducers - ESP

0 0 3	3 cm (1.2") – for metal transducers with NPT connections only
0 0 5	5 cm (2")
0 1 0	10 cm (4")
0 2 5	25 cm (10")

9M1 transducers - selectable

0 0 3	Minimum 3 cm (1.2") – for metal transducers with NPT connections only
0 0 5	Minimum 5 cm (2") – for all other connections
3 3 0	Maximum 330 cm (130")

9M2 transducers "A" length

specify "B" length separately (min 8 cm and max 318 cm between "A" and "B")

0 1 3	Minimum 13 cm (5.1") – for metal transducers with NPT connections only
0 1 5	Minimum 15 cm (5.9") – for all other connections
3 3 0	Maximum 330 cm (130")



complete order code for Echotel® transducer

→ X = product with a specific customer requirement

PRESSURE/TEMPERATURE RATINGS

Kynar® Transducer Ratings

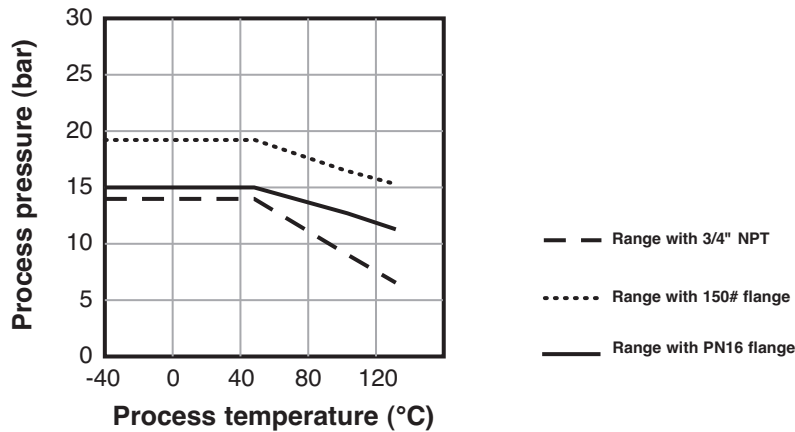

CPVC Transducer Ratings

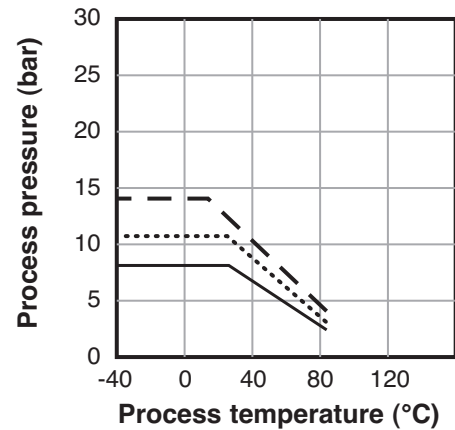

Metal Transducer Ratings

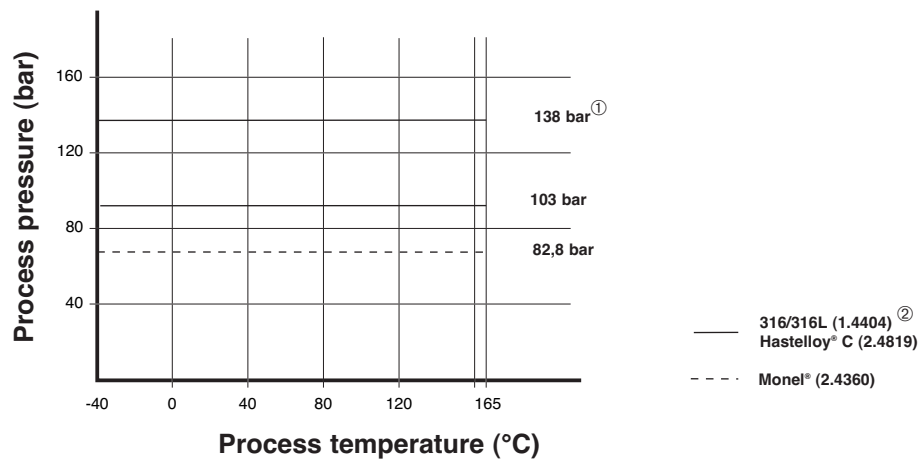

- ① Only applicable to NPT-connections with actuation length = 3 cm and all other connections with actuation length = 5 cm.
 ② For low temperature sensor: from -80 °C up to +120 °C.



QUALITY ASSURANCE - ISO 9001:2008

THE QUALITY ASSURANCE SYSTEM IN PLACE AT MAGNETROL® GUARANTEES THE HIGHEST LEVEL OF QUALITY DURING THE DESIGN, THE CONSTRUCTION AND THE SERVICE OF CONTROLS. OUR QUALITY ASSURANCE SYSTEM IS APPROVED AND CERTIFIED TO ISO 9001:2008 AND OUR TOTAL COMPANY IS COMMITTED TO PROVIDING FULL CUSTOMER SATISFACTION BOTH IN QUALITY PRODUCTS AND QUALITY SERVICE.

PRODUCT WARRANTY

ALL MAGNETROL® ELECTRONIC AND ULTRASONIC LEVEL CONTROLS ARE WARRANTED FREE OF DEFECTS IN MATERIALS AND WORKMANSHIP FOR ONE FULL YEAR FROM THE DATE OF ORIGINAL FACTORY SHIPMENT. IF RETURNED WITHIN THE WARRANTY PERIOD; AND, UPON FACTORY INSPECTION OF THE CONTROL, THE CAUSE OF THE CLAIM IS DETERMINED TO BE COVERED UNDER THE WARRANTY; THEN, MAGNETROL® INTERNATIONAL WILL REPAIR OR REPLACE THE CONTROL AT NO COST TO THE PURCHASER (OR OWNER) OTHER THAN TRANSPORTATION. MAGNETROL® SHALL NOT BE LIABLE FOR MISAPPLICATION, LABOR CLAIMS, DIRECT OR CONSEQUENTIAL DAMAGE OR EXPENSE ARISING FROM THE INSTALLATION OR USE OF THE EQUIPMENT. THERE ARE NO OTHER WARRANTIES EXPRESSED OR IMPLIED, EXCEPT, SPECIAL WRITTEN WARRANTIES COVERING SOME MAGNETROL® PRODUCTS.



BULLETIN N°:
EFFECTIVE:
SUPERSEDES:

BE 51-137.3
APRIL 2010
March 2008

UNDER RESERVE OF MODIFICATIONS

BENELUX FRANCE	Heikensstraat 6, 9240 Zele, België -Belgique Tel. +32 (0)52.45.11.11 • Fax. +32 (0)52.45.09.93 • E-Mail: info@magnetrol.be
DEUTSCHLAND	Alte Ziegelei 2-4, D-51491 Overath Tel. +49 (0)2204 / 9536-0 • Fax. +49 (0)2204 / 9536-53 • E-Mail: vertrieb@magnetrol.de
INDIA	C-20 Community Centre, Janakpuri, New Delhi - 110 0058 Tel. +91 (11) 41661840 • Fax +91 (11) 41661843 • E-Mail: info@magnetrolindia.com
ITALIA	Via Arese 12, I-20159 Milano Tel. +39 02 607.22.98 (R.A.) • Fax. +39 02 668.66.52 • E-Mail: mit.gen@magnetrol.it
U.A.E.	DAFZA Office 5EA 722 • PO Box 293671 • Dubai Tel. +971-4-6091735 • Fax +971-4-6091736 • E-Mail: info@magnetrol.ae
UNITED KINGDOM	Unit 1 Regent Business Centre, Jubilee Road Burgess Hill West Sussex RH 15 9TL Tel. +44 (0)1444 871313 • Fax +44 (0)1444 871317 • E-Mail: sales@magnetrol.co.uk

www.magnetrol.com

OUR NEAREST REPRESENTATIVE

Wesmar

Hugo Tillquist AB Tel: 08 594 632 00
Box 1120 Fax: 08 751 36 95
164 22 Kista info@wesmar.se