

## DESCRIPTION

Echotel® 960/961 ultrasonic level switches require no calibration to detect the presence of any liquid with a viscosity up to 10.000 cP in less than 1s. Foam is ignored by technology, so that the unit only detects the presence or absence of liquid. The pulsed wave technology permits the unit to resist turbulence, aeration, suspended solids and build up.

The Echotel® series have both 3A and EHEDG approval for use in hygienic applications.

Model 960 is equipped with AS-i bus communication.

Model 961 offers either current shift or relay output.

## FEATURES

- No calibration
- 2-wire loop powered with mA output, AC/DC line powered with integrated relays or 2-wire AS-i bus communication.
- Continuous selftest with selectable error output
- LED identification for:
  - process alarm
  - error of transducer, electronics or electrical noise interference
  - wet/dry status of transducer
- Push buttons for manual testing of alarm and error signals
- Adjustable time delay up to 45 s
- Suitable sensor design for CIP/SIP cleaning
- Model 961 suited for SIL 1 and SIL 2 loops (full FMEDA report available)



## APPLICATIONS

**MEDIA:** Any liquid with a viscosity < 10.000 cP.

**VESSELS:** Any mounting position.

**CONDITIONS:** Unaffected by

- shifting dielectric, density, or PH
- presence of foam, turbulence, visible vapours
- fast drain/fill rates
- vacuum conditions.

## For LIQUID LEVEL switching applications



## AGENCY APPROVALS<sup>①</sup>

Agency	Approval
TNO	Hygienic Machinery Directive 98/37/EC annex 1, section 2.1 EN 1672 part 2, Hygienic requirements EHEDG doc. 2 (second edit. March 2000) and doc. 8 (July 1993)
AS-i <sup>②</sup>	Tested to EN 50295/IEC 62026-2 test certificate # 76401
Other approvals are available, consult factory for more details	

<sup>①</sup> Refer to bulletin BE 51-137 for ATEX/FM/CSA approved units.

<sup>②</sup> For model 960 only.

## TECHNOLOGY

The Echotel® 960/961 operates on a two crystal pulsed or “transmit-receive” principle which applies a high frequency electronic burst to the transmit crystal. The signal is then converted into ultrasonic energy and transmitted across the sensing gap towards the receiver crystal. When there is air in the gap, the high frequency ultrasonic energy will be attenuated, thereby not allowing the energy to be received. When there is liquid in the gap, the ultrasonic energy will propagate across the gap and the output will indicate a reception of the signal.

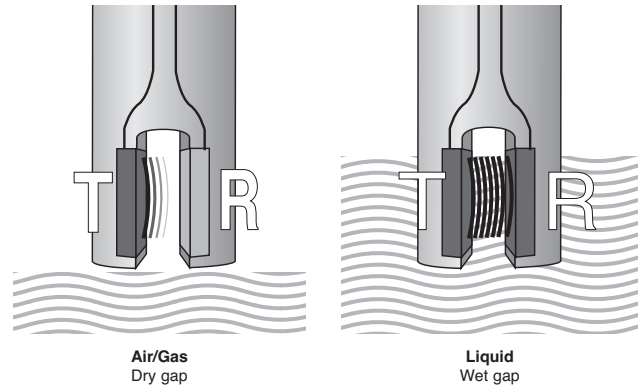

## MOUNTING

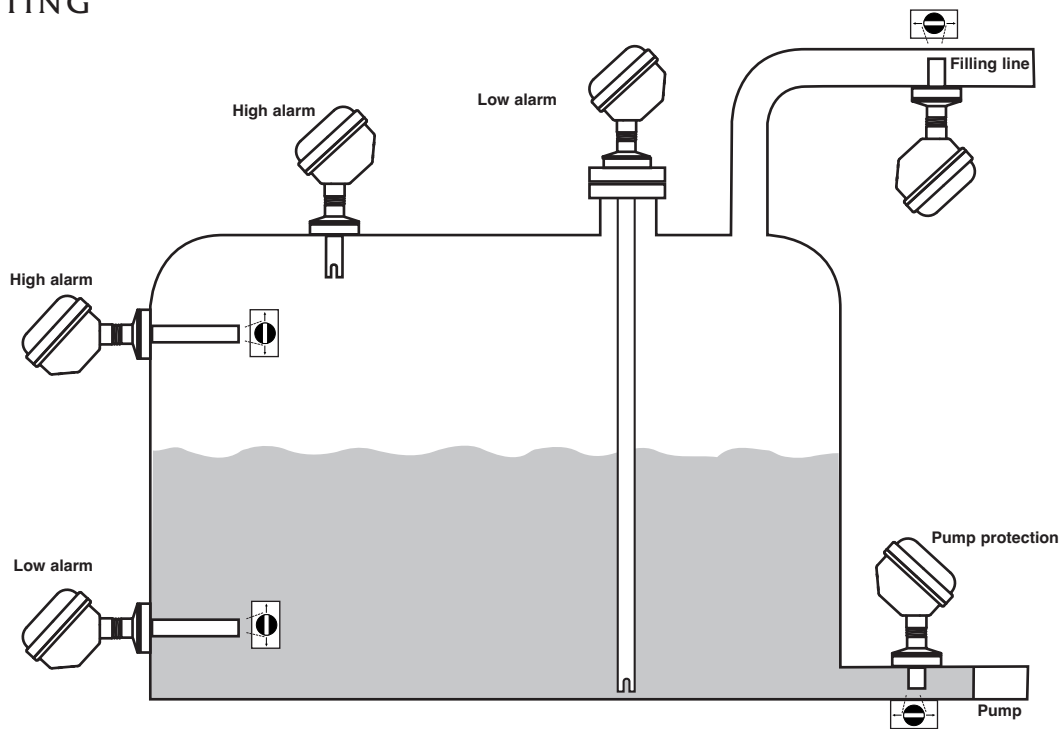

# ELECTRONICS



AS-i 960



Loop powered 961



Line powered 961

## FUNCTIONS

### Adjustable time delay:

The Echotel® 960/961 provides a fast response time of typically 0,5 s. In applications with turbulent or boiling surfaces, this may lead to scattering of the output. For these applications, the user can adjust via a potentiometer a time delay from 0,5 to 45 s and avoid false switching.

**Pushbuttons for manual check:** The alarm output and the error signal of the Echotel® 960/961 can be manually checked via pushbuttons. For loop powered units, the loop test pushbutton will sequentially check the shift of loop current. For relay operated units, the level test pushbutton will make the relay change from energized to de-energized status or vice versa. For AS-i bus units, data bit D2 will change from 1 to 0 and vice versa. Pressing the fault/malfunction pushbutton stops all transmit pulses, which simulates an electronics failure, and tests the selected output signal.

### LED identification:

The «Wet» LED reports liquid in the gap. An additional «Level» LED on the 961 with relay output reports alarm. With the current shift version (961), the corresponding 8 or 16 mA LED will report alarm or safe condition. «Fault» LED reports a malfunction of the unit. The blinking sequence of the LED identifies the failure (electronics, transducer or electrical noise interference). «Malfunction» LED (only for units with relay) confirms that the malfunction relay is energized in normal operation

### Selectable error signal:

The error signal of loop powered units (961) can be set for either 3,6 or 22 mA. The separate malfunction relay of the 961 can be set for independent or joint operation with the alarm relay. The 960 will report a malfunction in accordance to the AS-I protocol whereby data bit D3 will turn from 0 into 1.

## ELECTRICAL WIRING

### Loop powered

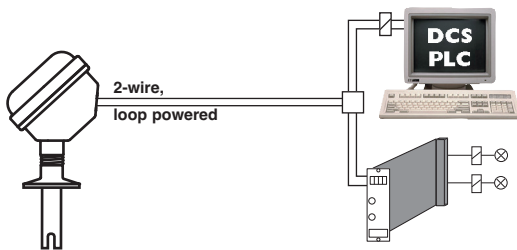

### Line powered

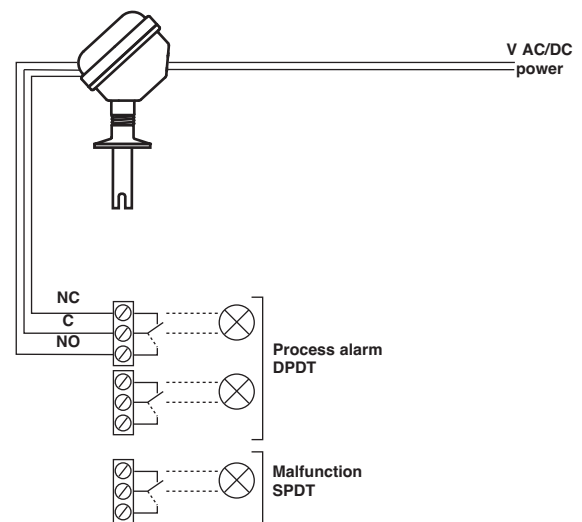

### AS-i bus

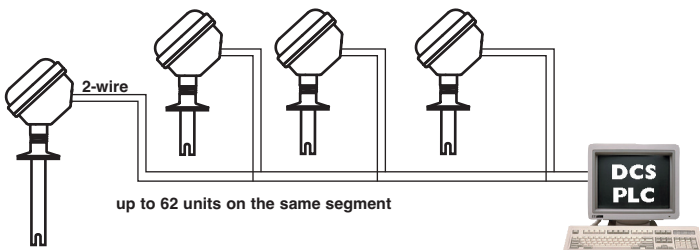

# SELECTION DATA

## A complete measuring system consists of:

1. ECHOTEL® electronics
2. ECHOTEL® transducer
3. Option: AS-i quick disconnect male connector M12 x 1 for 960 electronics: order code **037-7916-001**

### 1. Order code for Echotel® electronics

#### BASIC MODEL NUMBER Electronics with AS-i bus communication

9 6 0 - 5 8 A	24 V DC 2-wire loop powered electronics with AS-i bus communication
---------------	---

#### Electronics with mA or relay output

9 6 1 - 5 0 A	24 V DC 2-wire loop powered electronics with current shift output
9 6 1 - 2 D A	18 – 32 V DC line powered electronics with 5 A gold flash relay output
9 6 1 - 7 D A	102 – 265 V AC line powered electronics with 5 A gold flash relay output

#### ACCESSORIES

0	Blind housing cover
1	Housing cover with glass window

#### MOUNTING / HOUSING MATERIAL / APPROVAL <sup>① ②</sup>

**Integral mount electronics**  
304 SST – IP 67

0 7	Weatherproof
-----	--------------

- ① Other housing materials / approvals are available; refer to bulletin BE 51-137
- ② Consult factory for FM, CSA or other approvals

#### CABLE ENTRY

5	M20 x 1,5 (2 entries – 1 plugged)
---	-----------------------------------

9	6			A				0	7	5
---	---	--	--	---	--	--	--	---	---	---

**complete order code for Echotel® electronics**

→ X = product with a specific customer requirement

**2. Order code for Echotel® transducer**

**BASIC MODEL NUMBER**

9	M	1	Transducer with single setpoint
---	---	---	---------------------------------

**TRANSDUCER MATERIAL (0,5 µm Ra (20 Ra) surface finish)**

S	316/316L (1.4401/1.4404) stainless steel
---	--

**PROCESS CONNECTION – SIZE/TYPE ①**

3	T	A	1" - 1 1/2" Tri-clamp®
4	T	A	2" Tri-clamp®
B	S	A	DN 25 DIN 11851
C	S	A	DN 40 DIN 11851
D	S	A	DN 50 DIN 11851
V	V	A	DN 65 Varivent®

① Consult factory for other process connections (NEUMO BioControl®, G1A, ...)

**ACTUATION LENGTH – Specify per cm (0.39") increment**  
 Total insertion length = actuation length + 6 mm (0.25")

0	0	5	Minimum 5 cm (2")
3	3	0	Maximum 330 cm (130")

	9	M	1	S			A			
--	---	---	---	---	--	--	---	--	--	--

**complete order code for Echotel® transducer**

→ X = product with a specific customer requirement

DIMENSIONS IN mm (inches)

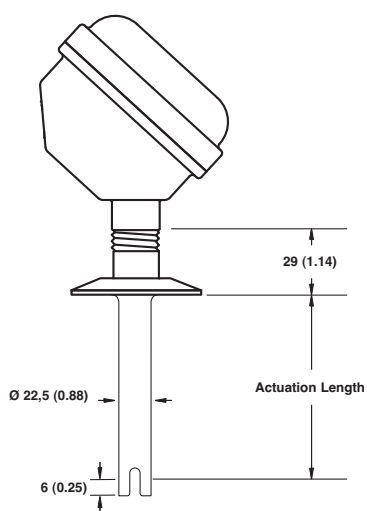
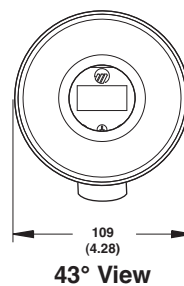
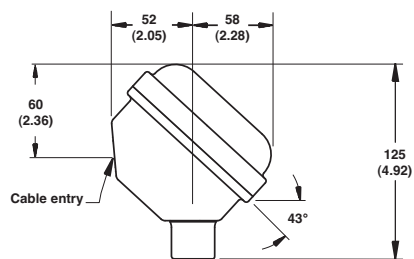

**Tri-Clamp®**

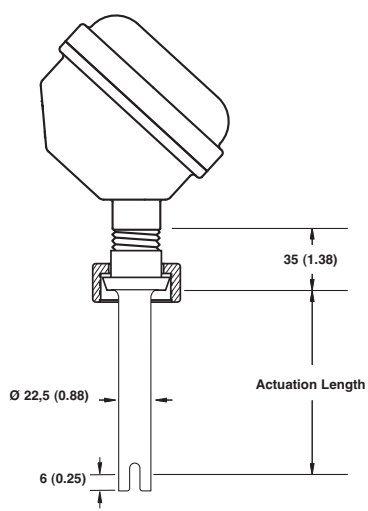

**DIN 11851**

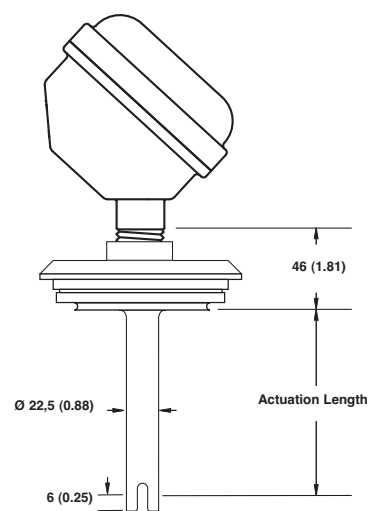

**Varivent®**

## ELECTRONICS SPECIFICATIONS

Description		Specification
Input Voltage	mA - version	2 wire loop powered, 11 - 35 V DC
	Relay - version	102 - 265 V AC 50/60 Hz or 18 - 32 V DC
	AS-i version	21-31 V DC (2-wire)
Power Consumption		< 3 Watt (relay version) – < 1 Watt (mA version / AS-i version)
Output	mA - version	8 mA (safe), 16 mA (alarm) ± 1 mA ≤ 3,6 or ≥ 22 mA error signal
	Relay - version	one 5 A DPDT level alarm relay, one 5 A SPDT malfunction relay
	AS-i version	data bit D2 = "1" with a wet gap / "0" with a dry gap data bit D3 = "1" during malfunction / "0" during normal operation
Time delay		0,5 to 45 s adjustable (in addition to transducer response time)
Indication		LED's for process alarm status (961), malfunction (error of transducer, electronics or electrical noise interference) and wet/dry status of transducer (960, 961 with relay)
Selftest	Automatic	Continuously verifies electronics, transducer and noise interference
	Manual	Via pushbutton for checking alarm output(s) and error output/function.
Housing material		304 stainless steel, IP 67
Approvals		EHEDG (per TNO) and 3A certification
SIL (Safety Integrity Level)①		Functional safety to SIL 2 as 1oo1 in accordance to IEC 61508 – SFF of 91,4 % (mA - version) and 92 % (relay - version). Full FMEDA report and declaration sheets available at request
Shock/Vibration Class		ANSI/ISA-S71.03 Class SA1 (shock), ANSI/ISA-S71.03 Class VC2 (vibration)
Net weight		1 kg (2.2 lbs) – electronics only
AS-i bus specifications	AS-i version	V3.0 (AS-i test certificate # 76401)
	Slave type	A/B (maximum of 62 nodes)
	Slave profile	S-0.A.E.
	Connectable load	EN 50295 and IEC 62026-2

① For model 961 only

## PERFORMANCE

Description		Specification
Response time		0,5 s typical
Repeatability		± 2 mm (0.078")
Ambient Temperature	960	-25 °C to +70 °C (-13 °F to +160 °F)
	961	-40 °C to +70 °C (-40 °F to +160 °F)
Humidity		0-99 %, non-condensing
Electromagnetic compatibility		Meets CE requirements (EN 61326: 1997 + A1 + A2) and NAMUR NE 21

## TRANSDUCER SPECIFICATIONS

Description		Specification
Material		316/316L (1.4401/1.4404)
Surface finish		0,5 µm Ra (20 Ra)
Process connection		Tri-Clamp®, DIN 11851, Varivent®
Transducer diameter		22,5 mm (0.88")
Transducer length	Max	330 cm (130")
	Min	5 cm (2")
Process temperature	Max	+165 °C (+325 °F)
	Min	-40 °C (-40 °F)
Max. process pressure		103 bar @ +40 °C (1500 psi @ +100 °F) 103 bar @ +165 °C (1500 psi @ +325 °F) Note: max. process pressure is downrated to the design pressure of the selected process connection



**ISO-9001:2008 REGISTERED FIRM**  
DNV Certification B.V., THE NETHERLANDS

#### QUALITY ASSURANCE - ISO 9001:2008

THE QUALITY ASSURANCE SYSTEM IN PLACE AT MAGNETROL® GUARANTEES THE HIGHEST LEVEL OF QUALITY DURING THE DESIGN, THE CONSTRUCTION AND THE SERVICE OF CONTROLS. OUR QUALITY ASSURANCE SYSTEM IS APPROVED AND CERTIFIED TO **ISO 9001:2008** AND OUR TOTAL COMPANY IS COMMITTED TO PROVIDING FULL CUSTOMER SATISFACTION BOTH IN QUALITY PRODUCTS AND QUALITY SERVICE.

#### PRODUCT WARRANTY

ALL MAGNETROL® ELECTRONIC AND ULTRASONIC LEVEL CONTROLS ARE WARRANTED FREE OF DEFECTS IN MATERIALS AND WORKMANSHIP FOR ONE FULL YEAR FROM THE DATE OF ORIGINAL FACTORY SHIPMENT. IF RETURNED WITHIN THE WARRANTY PERIOD; AND, UPON FACTORY INSPECTION OF THE CONTROL, THE CAUSE OF THE CLAIM IS DETERMINED TO BE COVERED UNDER THE WARRANTY; THEN, MAGNETROL® INTERNATIONAL WILL REPAIR OR REPLACE THE CONTROL AT NO COST TO THE PURCHASER (OR OWNER) OTHER THAN TRANSPORTATION. MAGNETROL® SHALL NOT BE LIABLE FOR MISAPPLICATION, LABOR CLAIMS, DIRECT OR CONSEQUENTIAL DAMAGE OR EXPENSE ARISING FROM THE INSTALLATION OR USE OF THE EQUIPMENT. THERE ARE NO OTHER WARRANTIES EXPRESSED OR IMPLIED, EXCEPT, SPECIAL WRITTEN WARRANTIES COVERING SOME MAGNETROL® PRODUCTS.



BULLETIN N°: BE 51-132.3  
EFFECTIVE: APRIL 2010  
SUPERSEDES: September 2009

#### UNDER RESERVE OF MODIFICATIONS

BENELUX FRANCE	Heikensstraat 6, 9240 Zele, België -Belgique Tel. +32 (0)52.45.11.11 • Fax. +32 (0)52.45.09.93 • E-Mail: info@magnetrol.be
DEUTSCHLAND	Alte Ziegelei 2-4, D-51491 Overath Tel. +49 (0)2204 / 9536-0 • Fax. +49 (0)2204 / 9536-53 • E-Mail: vertrieb@magnetrol.de
INDIA	C-20 Community Centre, Janakpuri, New Delhi - 110 0058 Tel. +91 (11) 41661840 • Fax +91 (11) 41661843 • E-Mail: info@magnetrolindia.com
ITALIA	Via Arese 12, I-20159 Milano Tel. +39 02 607.22.98 (R.A.) • Fax. +39 02 668.66.52 • E-Mail: mit.gen@magnetrol.it
U.A.E.	DAFZA Office 5EA 722 • PO Box 293671 • Dubai Tel. +971-4-6091735 • Fax +971-4-6091736 • E-Mail: info@magnetrol.ae
UNITED KINGDOM	Unit 1 Regent Business Centre, Jubilee Road Burgess Hill West Sussex RH 15 9TL Tel. +44 (0)1444 871313 • Fax +44 (0)1444 871317 • E-Mail: sales@magnetrol.co.uk

www.magnetrol.com

#### OUR NEAREST REPRESENTATIVE

**Wesmar**

Hugo Tillquist AB Tel: 08 594 632 00  
Box 1120 Fax: 08 751 36 95  
164 22 Kista info@wesmar.se