

MODEL R82

Non contact radar transmitter
for level and volume

DESCRIPTION

The Model R82 is an economical, loop-powered radar transmitter bringing radar to everyday applications. Daily applications that have been considered for Ultrasonic can now use radar technology with its superior performance.

The electronics are housed in a single compartment cast aluminium or Lexan® housing. The R82 measures effectively even when atmospheres above the liquid are saturated with vapour. Pulse Burst technology and advanced signal processing manage common disturbances such as false echoes caused by obstructions, multi-path reflections from tank sidewalls or turbulence caused by agitators, aggressive chemicals, or aerators.

FEATURES

- 2-wire, intrinsically safe loop powered
- 26 GHz frequency
- Fast and easy configuration via 2 x 16 character display and 4-pushbutton keypad
- Intuitive false target profiling
- Rotatable microwave beam for optimized operation
- Encapsulated Polypropylene or Tefzel® antennas in lengths of 50 mm (2") and 200 mm (8")
- Process
 - Temperature: -40 °C to +93 °C (-40 °F to +200 °F)
 - Pressure: Vacuum to 13,8 bar (200 psi)
 - Dielectric: 1,7 – 100

APPLICATIONS

- Open channel flow flumes and weirs
- Paint, ink and solvent tanks
- Chemical storage
- Thick and viscous media
- Batch and day tanks

Up to 12 m (40 ft) range



AGENCY APPROVALS

Agency	Approval
ATEX	II 1 G Ex ia IIC T4, intrinsically safe
cFMus ^①	
Russian Authorisation Standards ^①	
Other approvals are available, consult factory for more details	

^① Consult factory for proper model numbers and classifications.

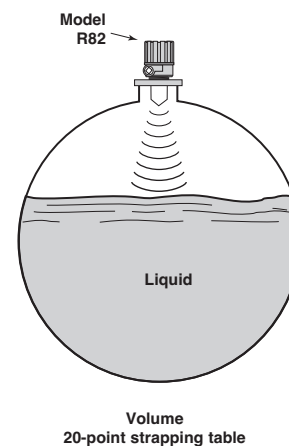
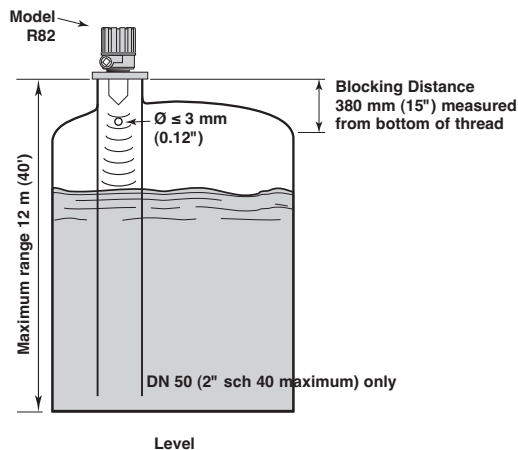

PRINCIPLE OF OPERATION

Model R82 Pulse Burst Radar emits short bursts of 26 GHz energy to a liquid surface. An ultra-high-speed timing circuitry measures the time of the signal reflected off the liquid surface.

Sophisticated signal processing filters out false reflections and other background noises. The exact level is then calculated, by factoring tank height and sensor offset information. The Model R82 circuitry is extremely energy efficient so no duty cycling is needed like with likewise radars. This allows to track high rates of level changes up to 4,5 m/minute (180"/min).

ORIENTATION

The R82 transmitter utilizes a linearly polarized, microwave beam that can be rotated to improve its performance. Proper orientation can minimize unwanted target reflections, decrease sidewall reflections (multipath) and maximize direct reflections from the liquid surface. The polarization pattern is parallel to the transmitter Display when the mechanism is at the #11 position. Each index number represents 10 degrees of rotation.

In a typical vertical tank, the Launcher should be adjusted so the polarization pattern is parallel to a line tangent to the nearest tank wall.

For horizontal cylindrical vessels aim beam down the long axis of the vessel.

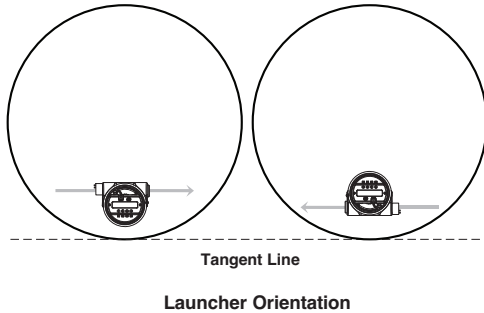

OPERATIONAL CONSIDERATIONS

Radar applications are characterized by three basic conditions:

- Dielectric
- Distance (measuring range)
- Disturbances (turbulence, foam, false targets, multiple reflections and rate of change)

Maximum measuring range (distance) is calculated as Tank Height + Sensor Offset. It is measured from the sensor reference point (bottom of NPT thread, top of BSP thread, or face of flange). The maximum distance chart shows the maximum measuring range of each antenna based on dielectric and turbulence.

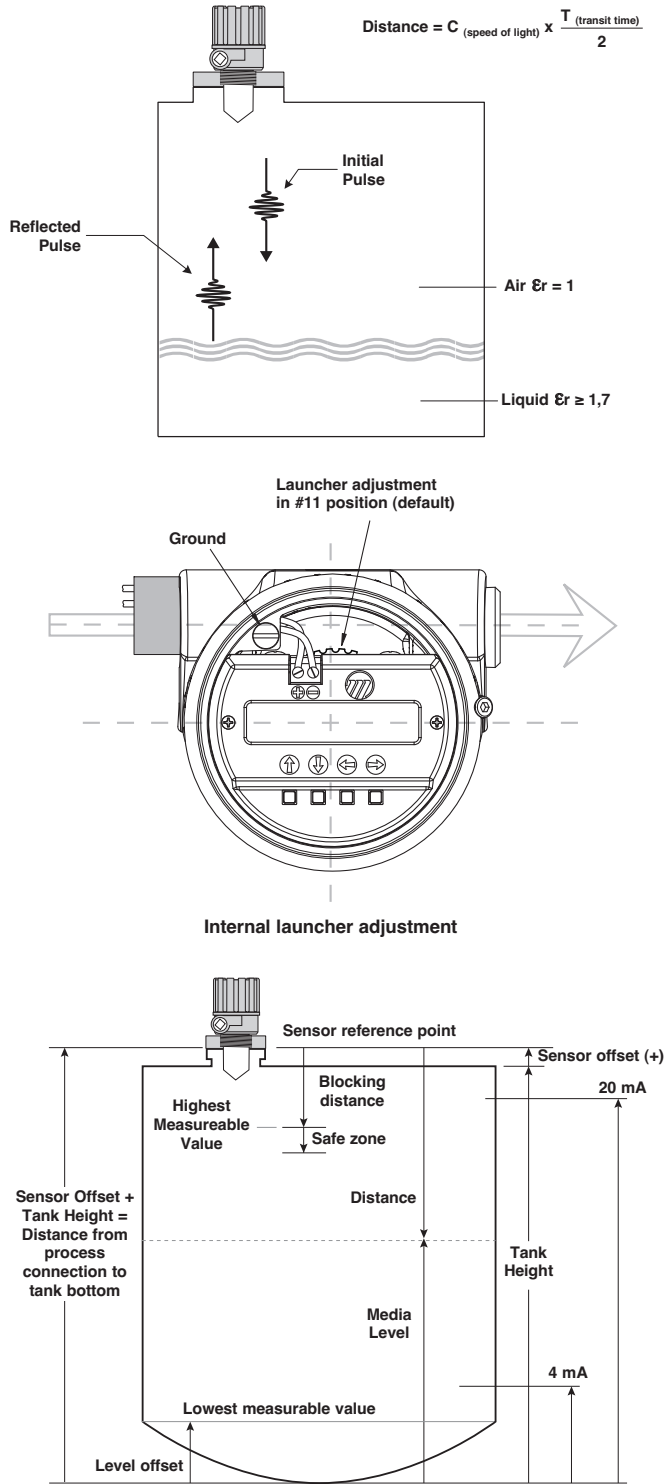

Turbulence	Wave height in mm (inch)	Maximum distance in m (ft)		
		εr: 1,7 - 3,0	εr: 3,0 - 10,0	εr: 10,0 - 100
None	—	7,9 (26)	10,1 (33)	12 (40)
Light	< 12,7 (0.5)	6,4 (21)	7,9 (26)	9,8 (32)
Moderate	12,7 - 25,4 (0.5 - 1.0)	4,3 (14)	5,8 (19)	7,3 (24)
Heavy	> 25,4 (1.0)	2,1 (7)	3,7 (12)	5,2 (17)

EXPEDITE SHIP PLAN (ESP)

Several models are available for quick shipment, within max. 4 weeks after factory receipt of purchase order, through the Expedite Ship Plan (ESP).

Models covered by ESP service are conveniently grey coded in the selection data charts.

To take advantage of ESP, simply match the colour grey model number codes (standard dimensions apply).

ESP service may not apply to orders of ten units or more. Contact your local representative for lead times on larger volume orders, as well as other products and options.

SELECTION DATA

1. Order code for Model R82 transmitter

BASIC MODEL NUMBER

R 8 2 - 5	24 V DC 2-wire loop powered non contact radar transmitter with HART®
-----------	--

MOUNTING / APPROVAL

A	Integral mount, Weatherproof
B	Integral mount, ATEX intrinsically safe

HOUSING / CABLE ENTRY

0	IP 66, Cast aluminium, 3/4" NPT cable entry (2 entries - 1 plugged)
1	IP 66, Cast aluminium, M20 x 1,5 cable entry (2 entries - 1 plugged)
6	IP 66, Lexan® plastic, 3/4" NPT cable entry (2 entries - 1 plugged)
7	IP 66, Lexan® plastic, M20 x 1,5 cable entry (single entry)

ACCESSORIES

A	Digital display and keypad
---	----------------------------

ANTENNA TYPE

0 1	Polypropylene antenna with 50 mm (2") extension
0 2	Polypropylene antenna with 200 mm (8") extension
0 3	Tefzel® antenna with 50 mm (2") extension
0 4	Tefzel® antenna with 200 mm (8") extension

PROCESS CONNECTION – SIZE/TYPE

1	Threaded 2" NPT	– Schedule 40 maximum
2	Threaded 2" BSP (G 2")	– Schedule 40 maximum

X	R	8	2	-	5	-	A	-	0
---	---	---	---	---	---	---	---	---	---

complete order code for Model R82 transmitter

→ X = product with a specific customer requirement

TRANSMITTER SPECIFICATIONS

FUNCTIONAL/PHYSICAL

Description	Specification	
Power (at terminals)	Weatherproof: 16 to 36 V DC / ATEX Intrinsically Safe: 16 to 28,4 V DC	
Output	4-20 mA with HART®, 3,8 mA to 20,5 mA useable (meets NAMUR NE 43)	
Span	380 mm (15") to 12 m (40') - depending process conditions	
Resolution	Analog: 0,01 mA Display: 0,1 cm (inch)	
Loop Resistance	400 Ω @ 20 mA - 24 V DC or 350 Ω @ 22 mA - 24 V DC	
Damping	Adjustable 0-45 s	
Diagnostic Alarm	Adjustable 3,6 mA, 22 mA, HOLD last output	
User Interface	HART® communicator, PACTware® and/or 4-button keypad	
Display	2-line x 16-character LCD	
Menu Language	English/Spanish/French/German	
Housing Material	IP 66/Aluminium A356T6 (< 0.20 % copper) or Lexan® Thermoplastic	
Approvals	ATEX II 1 G Ex ia IIC T4, intrinsically safe Other approvals are available, consult factory for more details	
SIL (Safety Integrity Level)	Functional safety to SIL 1 as 1oo1 in accordance to IEC 61508 – SFF of 89,1 %	
Electrical Data	Ui = 28,4 V, li = 94 mA, Pi = 0,67 W // Ui = 28 V, li = 120 mA, Pi = 0,84 W	
Equivalent Data	Ci = 5,5 nF, Li = 370 μH	
Shock/Vibration Class	ANSI/ISA-S71.03 SA1 (Shock), ANSI/ISA-S71.03 VC2 (Vibration)	
Net Weight	Cast aluminium	1,45 kg (3,2 lbs) incl. 50 mm (2") Polypropylene® antenna
	Lexan®	0,73 kg (1,6 lbs) incl. 50 mm (2") Polypropylene® antenna
Overall Dimensions	Max: H 376 mm (14.80") x W 101 mm (3.98") - cast alu housing and tall sensor Min: H 204 mm (8.03") x W 96 mm (3.78") - Lexan® housing and short sensor	

PERFORMANCE

Description	Specification
Linearity	± 5 mm (0,2") or 0,05 % of tank height, whichever is greater
Accuracy	± 0,02 % of span per °C, tank heights > 2,54 m (100")
Blocking distance	380 mm (15"), measured from bottom of thread
Resolution	2,5 mm (0,1")
Repeatability	< 2,5 mm (0,1") or 0,025 % of tank height
Response time	< 1 second
Warm-up time	30 seconds
Ambient temp.	-40 °C to +70 °C (-40 °F to +160 °F) (weatherproof up to +80 °C (+175 °F)) Display: -20 °C to +70 °C (-5 °F to +160 °F)
Humidity	0-99 %, non-condensing
Dielectric range	1,7 - 100
Process temp.	-40 °C to +93 °C (-40 °F to +200 °F)
Process pressure	Full vacuum up to 13,8 bar (200 psi)
Electromagnetic compatibility	Meets CE requirements (EN 61326: 1997 + A1 + A2)

DIMENSIONS in mm (inch)

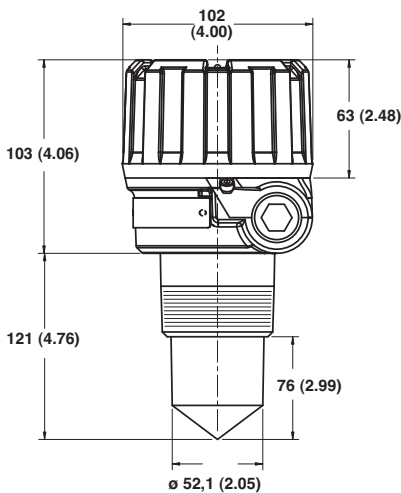

Cast aluminium housing with NPT short antenna

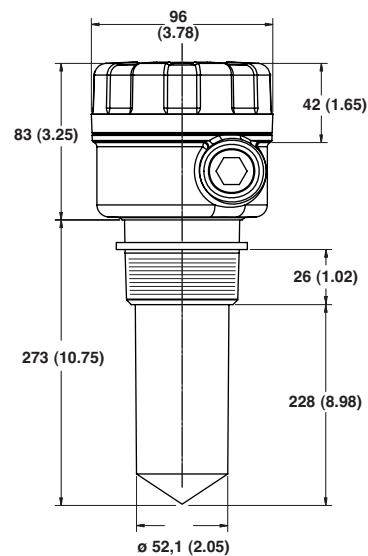

Lexan® housing with BSP extended antenna

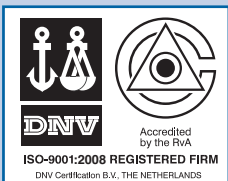

QUALITY ASSURANCE - ISO 9001:2008

THE QUALITY ASSURANCE SYSTEM IN PLACE AT MAGNETROL GUARANTEES THE HIGHEST LEVEL OF QUALITY DURING THE DESIGN, THE CONSTRUCTION AND THE SERVICE OF CONTROLS. OUR QUALITY ASSURANCE SYSTEM IS APPROVED AND CERTIFIED TO ISO 9001:2008 AND OUR TOTAL COMPANY IS COMMITTED TO PROVIDING FULL CUSTOMER SATISFACTION BOTH IN QUALITY PRODUCTS AND QUALITY SERVICE.

PRODUCT WARRANTY

ALL MAGNETROL ELECTRONIC AND ULTRASONIC LEVEL CONTROLS ARE WARRANTED FREE OF DEFECTS IN MATERIALS AND WORKMANSHIP FOR ONE FULL YEAR FROM THE DATE OF ORIGINAL FACTORY SHIPMENT. IF RETURNED WITHIN THE WARRANTY PERIOD; AND, UPON FACTORY INSPECTION OF THE CONTROL, THE CAUSE OF THE CLAIM IS DETERMINED TO BE COVERED UNDER THE WARRANTY; THEN, MAGNETROL INTERNATIONAL WILL REPAIR OR REPLACE THE CONTROL AT NO COST TO THE PURCHASER (OR OWNER) OTHER THAN TRANSPORTATION. MAGNETROL SHALL NOT BE LIABLE FOR MISAPPLICATION, LABOR CLAIMS, DIRECT OR CONSEQUENTIAL DAMAGE OR EXPENSE ARISING FROM THE INSTALLATION OR USE OF THE EQUIPMENT. THERE ARE NO OTHER WARRANTIES EXPRESSED OR IMPLIED, EXCEPT, SPECIAL WRITTEN WARRANTIES COVERING SOME MAGNETROL PRODUCTS.



BULLETIN N°:
EFFECTIVE:
SUPERSEDES:

BE 58-110.1
SEPTEMBER 2010
September 2009

UNDER RESERVE OF MODIFICATIONS

BENELUX FRANCE	Heikensstraat 6, 9240 Zele, België -Belgique Tel. +32 (0)52.45.11.11 • Fax. +32 (0)52.45.09.93 • E-Mail: info@magnetrol.be
DEUTSCHLAND	Alte Ziegelei 2-4, D-51491 Overath Tel. +49 (0)2204 / 9536-0 • Fax. +49 (0)2204 / 9536-53 • E-Mail: vertrieb@magnetrol.de
INDIA	C-20 Community Centre, Janakpuri, New Delhi - 110 0058 Tel. +91 (11) 41661840 • Fax +91 (11) 41661843 • E-Mail: info@magnetrolindia.com
ITALIA	Via Aresè 12, I-20159 Milano Tel. +39 02 607.22.98 (R.A.) • Fax. +39 02 668.66.52 • E-Mail: mit.gen@magnetrol.it
U.A.E.	DAFZA Office 5EA 722 • PO Box 293671 • Dubai Tel. +971-4-6091735 • Fax +971-4-6091736 • E-Mail: info@magnetrol.ae
UNITED KINGDOM	Unit 1 Regent Business Centre, Jubilee Road Burgess Hill West Sussex RH 15 9TL Tel. +44 (0)1444 871313 • Fax +44 (0)1444 871317 • E-Mail: sales@magnetrol.co.uk

www.magnetrol.com

OUR NEAREST REPRESENTATIVE

Wesmar

Hugo Tillquist AB Tel: 08 594 632 00
Box 1120 Fax: 08 751 36 95
164 22 Kista info@wesmar.se