

## Specifications ODS *Black-Line* 2 kHz series:



1, 5 & 10 kHz versions are available of all ODS Black-Line models.

Models Select-2:	ODS 20.5	ODS 115	ODS 150	ODS 200	ODS 250	ODS 450	ODS 750
<b>High &amp; Very High Target Temperature</b>	-	+	+	+	+	+	+
<b>Measurement data:</b>							
Measuring range (FS)	9 mm	30 mm	100 mm	200 mm	300 mm	500 mm	700 mm
Measuring range	16-25	100-130	100-200	100-300	100-400	200-700	400-1100
Center distance	20.5 mm	115 mm	150 mm	200 mm	250 mm	450 mm	750 mm
Resolution at minimum*)	0.0008 mm **)	0.002 mm	0.010 mm **)	0.05 mm	0.08 mm	0.1 mm	0.5 mm
Resolution at maximum*)	± 0.0008 mm **)	± 0.002 mm	± 0.010 mm **)	± 0.05 mm	± 0.08 mm	± 0.1 mm	± 0.5 mm
Linearity *)	± 0.0045 mm	± 0.030 mm	± 0.050 mm	± 0.10 mm	± 0.20 mm	± 0.3 mm	± 0.7 mm
Updating frequency ***)	2 kHz	2 kHz	2 kHz	2 kHz	2 kHz	2 kHz	2 kHz
Temperature deviation	± 0.03% FS/C°	± 0.03% FS/C°	± 0.03% FS/C°	± 0.03% FS/C°	± 0.03% FS/C°	± 0.03% FS/C°	± 0.03% FS/C°
Light source ( nm )	LASER (655)	LASER (655)	LASER (655)	LASER (655)	LASER (655)	LASER (655)	LASER (655)
Size of spot	Ø 0.1 mm	Ø 1 mm	Ø 1 mm	Ø 2 mm	Ø 2 mm	Ø 2 mm	Ø 4 mm
Laser protection class	IEC 2	IEC 2	IEC 2	IEC 2	IEC 2	IEC 2	IEC 2
<b>Output data:</b>		<b>Electrical data:</b>		<b>Environment data:</b>		<b>Physical data:</b>	
Analog output ***):	4-20 mA or 1-9 V DC	Supply voltage	22 - 36 VDC	Operating temperature	0 - +45 C°	Dimensions	136*146*50mm ☐)
Digital output ***):	RS232 or RS422	Power consumption	max 4.5 W	Storage temperature	-20 - +70 C°	Weight excl. Cable	1600 g
Ethernet output ☐☐):	Alternative to RS output			Humidity non condensing	Max 90 % RH	Cable length	2.5 m
Baud rates are selectable	Baud rate: 38400 ***):	1 kHz output frequency		Degree of protection	IEC IP65	Housing	Steel/ Aluminum/ Glass
Default setting:	Baud rate: 115200 ***):	2 kHz output frequency					

\*) Static measurement on white paper at measuring frequency of 2 kHz, without any averaging of the output signals. Resolution = 2 x Standard deviation.

\*\*) Data for digital output. Analog outputs Resolution & Reproducibility < 0.050 mm for ODS 150 and > 0.001 for ODS 20.5. 14 Bit DAC's are used for the conversion.

\*\*\*) The serial-115200 signal and analog output are always updated at the measuring frequency of 2 kHz, except if the Simple Average Filter is set to be active.

☐) The Dimensions of the ODS 20.5 Model is 136\*138\*50 mm.

☐☐) The Ethernet interface option can be used for distance measurement only.

*More information on back page >*

July 2010; Subject to change without notice.

## Measuring frequency 2 kHz

Output rates are user specified, as the sensor can be programmed to make an average of up to 200 measurements and output it as a single point.

All ODS Black-Line 2 kHz sensors have a programming/Select functionality. Group Mode is the main feature. In Group Mode a running average is calculated over a user specified number of measuring points. The user also programs the sensor to disregard a number of, usually all, bad (zero) measuring points before calculating the average value. The average values are calculated at full measuring frequency and are used for converting the analog signal(s). Several Median filters and other options like Level Mode available.

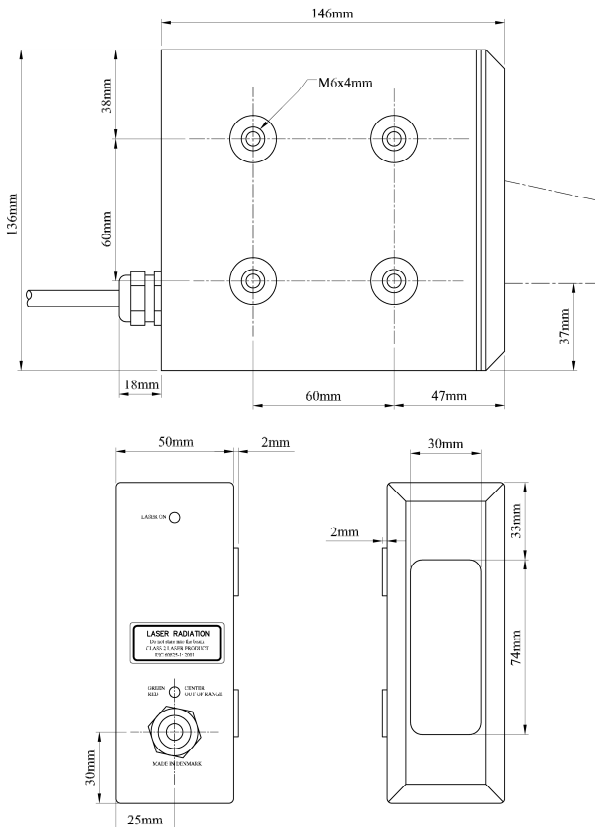

## ODS High Temperature models

The HT models are designed for target surfaces temperatures up to 1000 °C. The VHT models are designed for surface temperatures up to 1300 °C. The VVHT models are designed for target temperatures up to 2.200 °C using a **BLUE laser diode**.

Because of the non-contact measurement method, the ODS xxx HT sensors are specially designed for measurement on objects that are more than 450 °C hot like hot rolled steel or molten metals and glass. Laser class 2 sensors achieve target temperature up to 1.000 °C. VHT models can in laser class 3R form reach target temperatures of generally up to 1.300 °C and can in 3B form reach even higher. When using a Blue laser diode at 405 nm wavelengths up to 2.200 °C can be achieved.

Please note that the ODS 20.5 sensor is not available in HT, VHT and VVHT versions.

It is important to stress, that the HT specification only concerns the target temperature. Maximum sensor environment temperature is 45 °C.

The HT specification can also be necessary when there is a risk of harmful false light as is the case with bright sunlight, both direct and reflected.

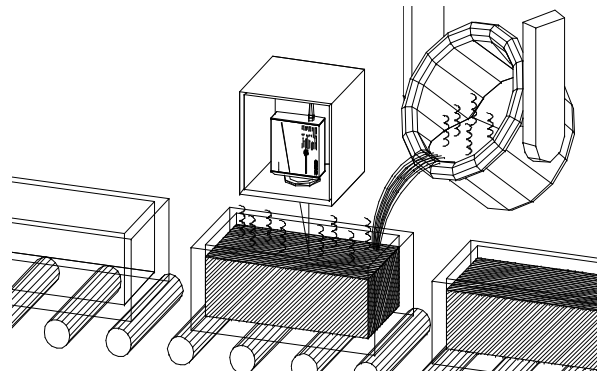

## ODS Thickness Measurement

ODS Black-Line sensors are calibrated for measuring thickness when paired.

An ODS Black-Line sensor will automatically turn itself into being either the Master or the Slave half part of a thickness measuring system when connected to an identical ODS sensor model.

The Master sensor reads the digital distance data send from the Slave sensor over their RS232 or RS422 serial interfaces, and after taking its own distance information into account, it will output the change in thickness in its calculated digital form as well as a converted analog signal. The sensors must always be synchronized, and will measure on transparent targets alternately from one side if they are wired to measure at 1 kHz (half) frequency.

A couple of ODS sensors will thus measure thickness or width without any control box or special calibration from the factory. ODS sensors can be programmed to operate in Difference Mode instead of measuring thickness. This unique characteristic of the ODS sensors are available in all models in the Black-, Grey- & Red-line families.

