

DESCRIPTION

T20 and T21 units are simple, reliable float switches designed for top mounting to tanks or vessels. T20 units utilize a single switch mechanism and float. T21 units utilize two switch mechanisms and two separate floats when widely spaced actuating levels are required. T20 and T21 models are available for any type of open or closed vessel with either threaded or flanged type mounting and actuating depths up to 1219 mm (48 inches).

FEATURES

- Carbon or stainless steel process connection materials (other materials available at request)
- Flanged and threaded process connections
- Process temperature up to 400 °C (750 °F)
- Up to 2 switch levels (T21)
- Specific gravity as low as 0,60
- Process pressure up to 41,3 bar (600 psi)
- Standard anti corrosive protection

Optional:

- NACE construction (MR-01-75)
- Interface calibration
- Special actuating levels
- Special tank connections
- Extreme temperature modifications
- Class 1, Group B explosion proof electrical enclosure
- Special exterior surface preparation and finish

APPLICATIONS

- Day Tanks
- Condensate Receivers
- Fuel Storage Tanks
- Cooling Towers
- Flash Tanks
- Interface

Float level switches for single or dual level alarm



AGENCY APPROVALS

Agency	Approval
ATEX	II 2G EEx d II C T6, explosion proof II 1G EEx ia II C T6, intrinsically safe
CENELEC	EEx d II C T6, explosion proof
CCE ^①	R1 (1) 136/MI/433, explosion proof
FM	Class I, Div. 1, Groups C & D Class II, Div. 1, Groups E, F & G, Type NEMA 7/9
FM/CSA ^②	Non-Hazardous area Explosion proof area – Groups B, C, D, E, F & G Type NEMA 4X/7/9
SAA ^②	Explosion proof area
LRS	Lloyds Register of Shipment (marine applications)
GOST/ GOSGORTECHNADZOR ^②	Russian Authorisation Standards
Other approvals are available, consult factory for more details	

^① For CCE approved units, use the ATEX explosion proof model numbers.

^② Consult factory for proper model numbers.

PRINCIPLE OF OPERATION

A permanent magnet (A) is attached to a pivoted switch (B). As the float (C) rises following the liquid level, it raises the magnet attractor (D) into the field of the magnet, which in turn snaps against the non-magnetic barrier tube (E), tilting the switch. The barrier tube provides a static seal between the switch mechanism and the float, eliminating the need for a flexing bellows seal, packing gland or other failure prone sealing elements.

When the liquid level falls, the float draws the magnet attractor below the magnetic field. The magnet swings out and tilts the switch to the reverse position causing low level switch actuation (A).

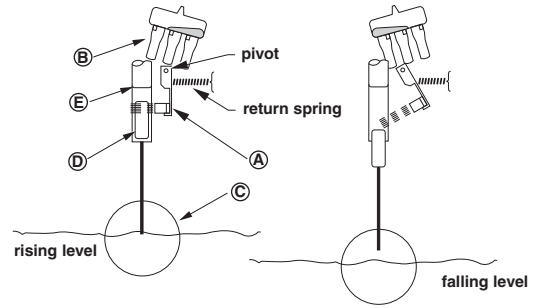

MOUNTING

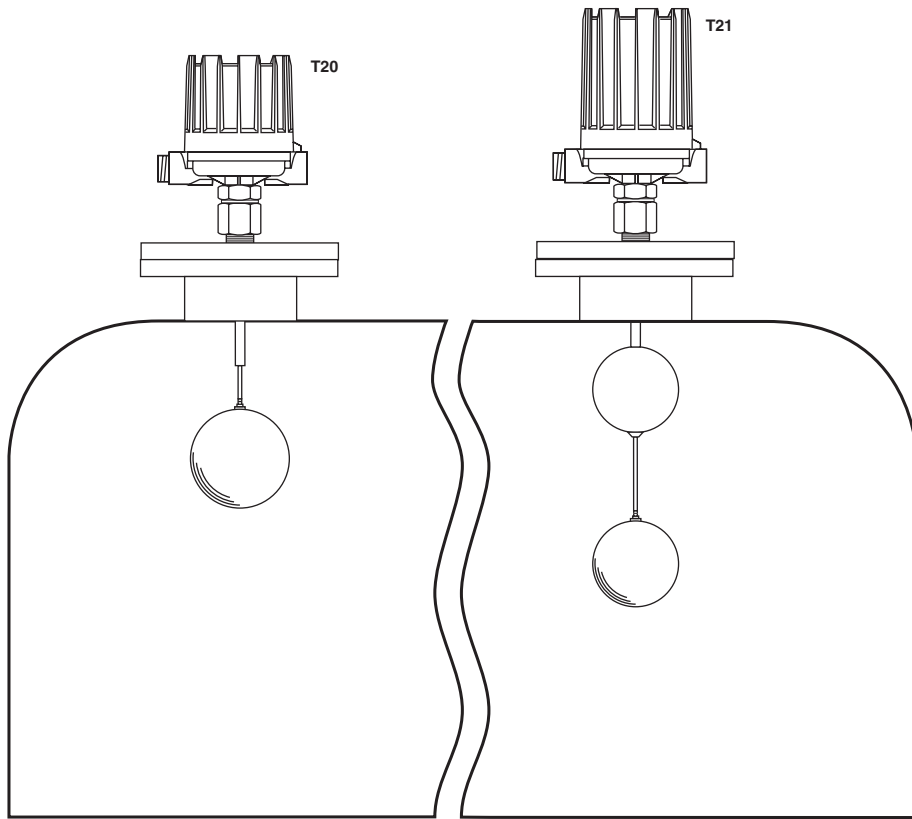

T20 – SINGLE SWITCH MODEL

Level alarm applications
Narrow differential type

These instruments are factory calibrated to operate over a narrow level differential band and are ideally suited for liquid level alarm applications, on either high or low level.

T21 – DUAL SWITCH MODEL

Level alarm applications
Narrow differential type

These instruments utilize two switches, each actuated at a different level and each calibrated with a narrow differential band.

AVAILABLE SWITCH MECHANISMS

Type of switch module ^①	Max. Process Temp. ^②	Switch ratings – A res. ^③			Code
		24 V DC	240 V AC	120 V AC	
Micro switch	max 120 °C (250 °F)	6	15	15	B
Micro switch	max 230 °C (450 °F)	10	15	15	C
Micro switch - DC current	max 120 °C (250 °F)	10	–	10	D
Micro switch with gold alloy contacts	max 120 °C (250 °F)	1	–	1	U
Hermetically sealed micro switch	max 290 °C (550 °F)	5	5	5	HS ^④
Hermetically sealed micro switch with silver plated contacts	max 230 °C (450 °F)	3	1	1	W
Hermetically sealed micro switch with gold plated contacts	max 230 °C (450 °F)	0,5	0,5	0,5	X
Hermetically sealed micro switch	max 400 °C (750 °F)	4	–	2,5	F
Proximity switch - type SJ 3.5 SN	max 100 °C (210 °F)	NA	NA	NA	V
Mercury switch	max 290 °C (550 °F)	10	6,5	13	A
Mercury switch	max 400 °C (750 °F)	10	6,5	13	3
Pneumatic bleed type (open air)	max 200 °C (400 °F)	NA	NA	NA	J
Pneumatic non bleed type (closed circuit)	max 200 °C (400 °F)	NA	NA	NA	K

^① For applications with heavy vibration, consult factory for suited switch modules.

^② Max process temperature is specified at 40 °C (100 °F) ambient temperature and for non condensing applications.

^③ For more details - see bulletin BE 42-120.

^④ For condensing applications, max process temperature is down-rated to 200 °C (400 °F) @ 40 °C (100 °F) ambient.

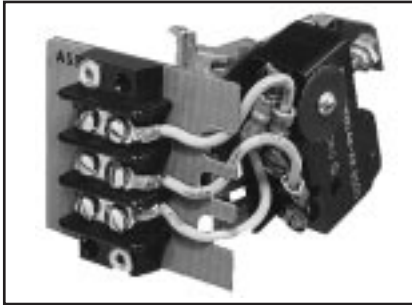

Type B, C, D & U



Type HS

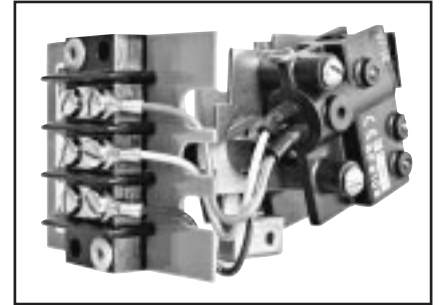

Type F, W & X

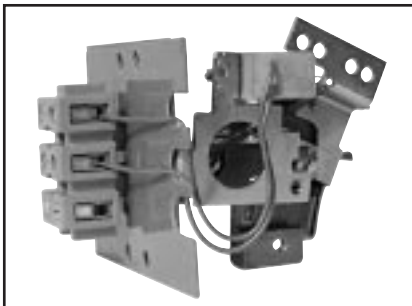

Type V



Type A & 3



Type J & K

AVAILABLE HOUSINGS



- For Non Ex use
- IP 66
- Die cast Aluminium
- 2 Entries (one plugged)
- Standard blue anti corrosive coating
- Housing heater/drain available, consult factory



- For Exd/Exi use
- IP 66
- Die cast Aluminium
- 2 Entries (one plugged)
- Standard blue anti corrosive coating
- ATEX II 2G EEx d II C T6
- ATEX II 1G EEx ia II C T6



- For Exd use
- IP 66
- Cast Iron
- One entry (2 entries at request)
- Standard blue anti corrosive coating
- CENELEC EEx d II C T6



- For pneumatic switches
- IP 53 (NEMA 3R)
- IP 55 optional at request
- Alu base / cold rolled steel cover
- Standard blue anti corrosive coating



- For Exd use
- IP 66 (NEMA 7/9)
- Die cast Aluminium
- 2 Entries (one plugged)
- Standard blue anti corrosive coating
- FM, Class I, Div. 1, Groups C & D
- FM, Class II, Div. 1, Groups E, F & G

FLOAT SELECTION AND MAX ACTUATING LEVEL (see page 7 for more details)

T20 models - float sizes			
Specific Gravity	ø 76 x 127 mm (3" x 5")	ø 102 mm (4")	ø 114 mm (4 1/2")
0.60	-	-	140 (5.5)
0.70	-	-	914 (36)
0.80	-	254 (10)	1219 (48)
0.90	432 (17)	813 (32)	1219 (48)
1.00	889 (35)	1219 (48)	1219 (48)

T21 models - float sizes ^①			
Specific Gravity	ø 76 x 127 mm (3" x 5")	ø 102 mm (4")	ø 114 mm (4 1/2")
0.70	-	-	711 (28)
0.80	-	305 (12)	1219 (48)
0.90	406 (16)	660 (26)	1219 (48)
1.00	711 (28)	1016 (40)	1219 (48)

^① Max actuating levels as per lowest float

EXPEDITE SHIP PLAN (ESP)

Several mechanical switches are available for quick shipment, within max. 3 weeks after factory receipt of purchase order, through the Expedite Ship Plan (ESP).

Models covered by ESP service are conveniently grey coded in the selection data charts.

To take advantage of ESP, simply match the grey coded model number codes (standard dimensions apply).

ESP service may not apply to orders of ten units or more. Contact your local representative for lead times on larger volume orders, as well as other products and options.

SELECTION DATA

A complete measuring system consists of:

- Order code for **top mounted** models (each unit can be factory calibrated when specific level differentials are specified separately – specify actuating level(s) for either rising or falling level and operating S.G.)
- Order code for **modified** models or adders: put an "X" in front of the closest matching order code and specify the modifications/adders separately
eg. XT20-AB2A-AAP X = with material certification EN 10204 / DIN 50049-3.1.B

1. Order code for top mounting liquid float level switches

BASIC MODEL NUMBER

T 2 0	single float	- top mounted liquid float level switch
T 2 1	tandem float	- top mounted liquid float level switch

MATERIALS OF CONSTRUCTION

Code	Process connection material	Float and trim	Magnetic sleeve
A	Carbon steel	316 SST (1.4401)	400 series SST
B			316 SST (1.4401)
D			316 (1.4401)

PROCESS CONNECTION

	Float sizes					
	ø 76 x 127 mm (3" x 5")		ø 102 mm (4")		ø 114 mm (4 1/2")	
Threaded NPT connection - for T20 models only						
1"	B2A		B2B		B2C	
ANSI Flanges - for all models						
	150 lbs RF	300 lbs RF	150 lbs RF	300 lbs RF	150 lbs RF	300 lbs RF
4"	H3A	H4A	-	-	-	-
5"	J3A	-	J3B	-	J3C	-
6"	K3A	K4A	K3B	K4B	K3C	K4C
DIN flanges form to DIN 2526 - for all models						
	PN 16 Form C	PN 25/40 Form C	PN 16 Form C	PN 25/40 Form C	PN 16 Form C	PN 25/40 Form C
DN 100	8FA	8GA	-	-	-	-
DN 150	9FA	9GA	9FB	9GB	9FC	9GC

SWITCH MECHANISM & ENCLOSURE (see page 5)



complete order code for top mounted models

Select electric switch mechanism & enclosure for **models T20** (see page 3 for switch ratings)

qty and switch type	All models with material code A										All models with material codes B & D									
	Weather proof (IP 66)		ATEX (IP 66)				CENELEC (IP 66)		FM (IP 66)		Weather proof (IP 66)		ATEX (IP 66)				CENELEC (IP 66)		FM (IP 66)	
			II 2G EEx d IIC T6		II 1G EEx ia II C T6		EEx d IIC T6		NEMA 7/9				II 2G EEx d IIC T6		II 1G EEx ia II C T6		EEx d IIC T6		NEMA 7/9	
	cast Aluminium	cast Aluminium	cast Aluminium	cast Aluminium	cast Iron	cast Alu.	cast Aluminium	cast Aluminium	cast Aluminium	cast Iron	cast Alu.	cast Aluminium	cast Aluminium	cast Aluminium	cast Iron	cast Alu.				
M20 x 1,5	1" NPT	M20 x 1,5	1" NPT	M20 x 1,5	1" NPT	M20 x 1,5	3/4" NPT	1" NPT	M20 x 1,5	1" NPT	M20 x 1,5	1" NPT	M20 x 1,5	1" NPT	M20 x 1,5	3/4" NPT	1" NPT			
A	1 x SPDT	A2P	AAP	AHC	AAC	-	-	AK7	AU7	AKP	A2Q	AAQ	AH9	AA9	-	-	AK5	AU5	AKQ	
	1 x DPDT	A8P	ADP	AJC	ABC	-	-	AD7	AW7	ANP	A8Q	ADQ	AJ9	AB9	-	-	AD5	AW5	ANQ	
	1 x SPDT	32P	3AP	3HC	3AC	-	-	3K7	3U7	3KP	32Q	3AQ	3H9	3A9	-	-	3K5	3U5	3KQ	
	1 x DPDT	38P	3DP	3JC	3BC	-	-	3D7	3W7	3NP	38Q	3DQ	3J9	3B9	-	-	3D5	3W5	3NQ	
B	1 x SPDT	B2P	BAP	BHC	BAC	-	-	BK7	BU7	BKP	B2Q	BAQ	BH9	BA9	-	-	BK5	BU5	BKQ	
	1 x DPDT	B8P	BDP	BJC	BBC	-	-	BD7	BW7	BNP	B8Q	BDO	BJ9	BB9	-	-	BD5	BW5	BNQ	
C	1 x SPDT	C2P	CAP	CHC	CAC	C2L	CAL	CK7	CU7	CKP	C2Q	CAQ	CH9	CA9	C2S	CAS	CK5	CU5	CKQ	
	1 x DPDT	C8P	CDP	CJC	CBC	C8L	CDL	CD7	CW7	CNP	C8Q	CDQ	CJ9	CB9	C8S	CDS	CD5	CW5	CNQ	
D	1 x SPDT	-	-	-	-	-	-	-	-	-	D2Q	DAQ	DH9	DA9	-	-	DK5	DU5	DKQ	
	1 x DPDT	-	-	-	-	-	-	-	-	-	D8Q	DDQ	DJ9	DB9	-	-	DD5	DW5	DNQ	
F	1 x SPDT	F2P	FAP	FHC	FAC	-	-	FK7	FU7	FKP	F2Q	FAQ	FH9	FA9	-	-	FK5	FU5	FKQ	
	1 x DPDT	F8P	FDP	FJC	FBC	-	-	FD7	FW7	FNP	F8Q	FDQ	FJ9	FB9	-	-	FD5	FW5	FNQ	
HS	1 x SPDT	-	-	-	-	-	-	-	-	-	H7A	HM2	HFC	HA9	-	-	HB3	HB4	HM3	
	1 x DPDT	-	-	-	-	-	-	-	-	-	H7C	HM6	HGC	HB9	-	-	HB7	HB8	HM7	
U	1 x SPDT	U2P	UAP	UHC	UAC	U2L	UAL	UK7	UU7	UKP	U2Q	UAQ	UH9	UA9	U2S	UAS	UK5	UU5	UKQ	
	1 x DPDT	U8P	UDP	UJC	UBC	U8L	UDL	UD7	UW7	UNP	U8Q	UDQ	UJ9	UB9	U8S	UDS	UD5	UW5	UNQ	
V	-	-	-	-	VFS	VHS	-	-	-	-	-	-	-	V5S	VBS	-	-	-		
W	1 x SPDT	W2P	WAP	WHC	WAC	W2L	WAL	WK7	WU7	WKP	W2Q	WAQ	WH9	WA9	W2S	WAS	WK5	WU5	WKQ	
	1 x DPDT	-	-	-	-	-	-	-	-	-	W8Q	WDQ	WJ9	WB9	W8S	WDS	WD5	WV5	WNQ	
X	1 x SPDT	X2P	XAP	XHC	XAC	X2L	XAL	XK7	XU7	XKP	X2Q	XAQ	XH9	XA9	X2S	XAS	XK5	XU5	XKQ	
	1 x DPDT	-	-	-	-	-	-	-	-	-	X8Q	XDQ	XJ9	XB9	X8S	XDS	XD5	XV5	XNQ	

Select pneumatic switch mechanism & enclosure - for **models T20** only

Pneumatic switch type	Max supply pressure bar (psi)	Max liquid temperature °C (°F)	Bleed orifice Ø mm (inches)	NEMA 3R (IP 53)	
				Material code A	Material codes B & D
Series J (open air)	6,9 (100)	200 (400)	1,60 (0.063)	JDG	JDE
	4,1 (60)	200 (400)	2,39 (0.094)	JEG	JEE
	4,1 (60)	370 (700)	1,40 (0.055)	JFG	JFE
Series K (closed circuit)	6,9 (100)	200 (400)	-	KOE	KOE
	2,8 (40)	200 (400)	-	KOG	-

Select electric switch mechanism & enclosure for **models T21** (see page 3 for switch ratings)

qty and switch type	All models with material code A										All models with material codes B & D									
	Weather proof (IP 66)		ATEX (IP 66)				CENELEC (IP 66)		FM (IP 66)		Weather proof (IP 66)		ATEX (IP 66)				CENELEC (IP 66)		FM (IP 66)	
			II 2G EEx d II C T6		II 1G EEx ia II C T6		EEx d II C T6		NEMA 7/9				II 2G EEx d II C T6		II 1G EEx ia II C T6		EEx d II C T6		NEMA 7/9	
	cast Aluminium	cast Aluminium	cast Aluminium	cast Aluminium	cast Iron	cast Alu.	cast Aluminium	cast Aluminium	cast Aluminium	cast Iron	cast Alu.	cast Aluminium	cast Aluminium	cast Aluminium	cast Iron	cast Alu.				
M20 x 1,5	1" NPT	M20 x 1,5	1" NPT	M20 x 1,5	1" NPT	M20 x 1,5	3/4" NPT	1" NPT	M20 x 1,5	1" NPT	M20 x 1,5	1" NPT	M20 x 1,5	1" NPT	M20 x 1,5	3/4" NPT	1" NPT			
A	2 x SPDT	A4A	ABA	ALC	ADC	-	-	AL7	AV7	ALA	A4B	ABB	AL9	AD9	-	-	AL5	AV5	ALB	
	2 x DPDT	A1A	AEA	APC	AGC	-	-	A07	AY7	AOA	A1B	AEB	AP9	AG9	-	-	A05	AY5	AOB	
3	2 x SPDT	34E	3BA	39E	3DE	-	-	3L7	3V7	3LE	34B	3BB	3L9	3D9	-	-	3L5	3V5	3LB	
	2 x DPDT	31A	3EA	3PC	3GC	-	-	307	3Y7	30A	31B	3EB	3P9	3G9	-	-	305	3Y5	30B	
B	2 x SPDT	B4A	BBA	BLC	BDC	-	-	BL7	BV7	BLA	B4B	BBB	BL9	BD9	-	-	BL5	BV5	BLB	
	2 x DPDT	B1A	BEA	BPC	BGC	-	-	B07	BY7	BOA	B1B	BEB	BP9	BG9	-	-	B05	BY5	BOB	
C	2 x SPDT	C4A	CBA	CLC	CDC	C4X	CBX	CL7	CV7	CLA	C4B	CBB	CL9	CD9	C4T	CBT	CL5	CV5	CLB	
	2 x DPDT	C1A	CEA	CPC	CGC	C1X	CEX	C07	CY7	COA	C1B	CEB	CP9	CG9	C1T	CET	C05	CY5	COB	
D	2 x SPDT	D4B	DBB	DL9	DD9	-	-	DL5	DV5	DLB	D4B	DBB	DL9	DD9	-	-	DL5	DV5	DLB	
	2 x DPDT	D1B	DEB	DP9	DG9	-	-	D05	DY5	DOB	D1B	DEB	DP9	DG9	-	-	D05	DY5	DOB	
F	2 x SPDT	FFA	FBA	FLC	FDC	-	-	FL7	FV7	FLA	FFB	FBB	FL9	FD9	-	-	FL5	FV5	FLB	
	2 x DPDT	FHA	FEA	FPC	FGC	-	-	F07	FY7	FOA	FHB	FEB	FP9	FG9	-	-	F05	FY5	FOB	
U	2 x SPDT	U4A	UBA	ULC	UDC	U4X	UBX	UL7	UV7	ULA	U4B	UBB	UL9	UD9	U4T	UBT	UL5	UV5	ULB	
	2 x DPDT	U1A	UEA	UPC	UGC	U1X	UEX	U07	UY7	UOA	U1B	UEB	UP9	UG9	U1T	UET	U05	UY5	UOB	
W	2 x SPDT	W4A	WBA	WLC	WDC	W4X	WBX	WL7	WV7	WLA	W4B	WBB	WL9	WD9	W4T	WBT	WL5	WV5	WLB	
	2 x DPDT	W1B	WEB	WP9	WG9	W1T	WET	W05	WY5	WOB	W1B	WEB	WP9	WG9	W1T	WET	W05	WY5	WOB	
X	2 x SPDT	X4A	XBA	XLC	XDC	X4X	XBX	XL7	XV7	XLA	X4B	XBB	XL9	XD9	X4T	XBT	XL5	XV5	XLB	
	2 x DPDT	X1B	XEB	XP9	XG9	X1T	XET	X05	XY5	XOB	X1B	XEB	XP9	XG9	X1T	XET	X05	XY5	XOB	

PHYSICAL SPECIFICATIONS

Description		Specification
Measured variable		Liquid level / interface level
Physical range		Standard models: min S.G. 0,60 (T20) – 0,70 (T21)
Process temperature Process pressure (for higher ratings consult factory)	ø 76 x 127 mm (3" x 5") float	Up to 34,5 bar (500 psi) @ 40 °C (100 °F) Up to 400 °C (750 °F) @ 20,7 bar (300 psi)
	ø 102 mm (4") float	Up to 41,3 bar (600 psi) @ 40 °C (100 °F) Up to 400 °C (750 °F) @ 27,6 bar (400 psi)
	ø 114 mm (4 1/2") float	Up to 34,5 bar (500 psi) @ 40 °C (100 °F) Up to 400 °C (750 °F) @ 23,4 bar (340 psi)
Process connection material		carbon steel or stainless steel (others at request)
Wetted materials	Float and trim	316 SST (1.4401)
	Magnetic sleeve	316 SST (1.4401) or 400 series SST

ELECTRICAL SPECIFICATIONS

Description	Specification
Switch ratings	Up to 15 A @ 240 V AC (depending on switch mechanism) Up to 10 A @ 120 V DC (depending on switch mechanism)
Signal Output	Single or dual SPDT or DPDT contacts (dual contacts for T21 models only) or single pneumatic
Switch Types (see table on page 3)	Dry contact with standard or gold alloy contacts, Mercury, Hermetically sealed, Hermetically sealed with gold or silver plated contacts, Proximity switch, or single pneumatic bleed and non bleed
Approvals (see table on page 1)	ATEX II 2G EEx d II C T6, explosion proof ATEX II 1G EEx ia II C T6, intrinsically safe CENELEC EEx d II C T6, explosion proof FM/CSA/SAA, explosion proof LRS, Lloyds Register of Shipment (marine applications) GOST/GOSGORTECHNADZOR, Russian Authorisation standards Other approvals are available, consult factory.
Cable entries	M20 x 1,5 ISO, 1" NPT and 3/4" NPT (or others at request)

ELECTRICAL CONNECTION

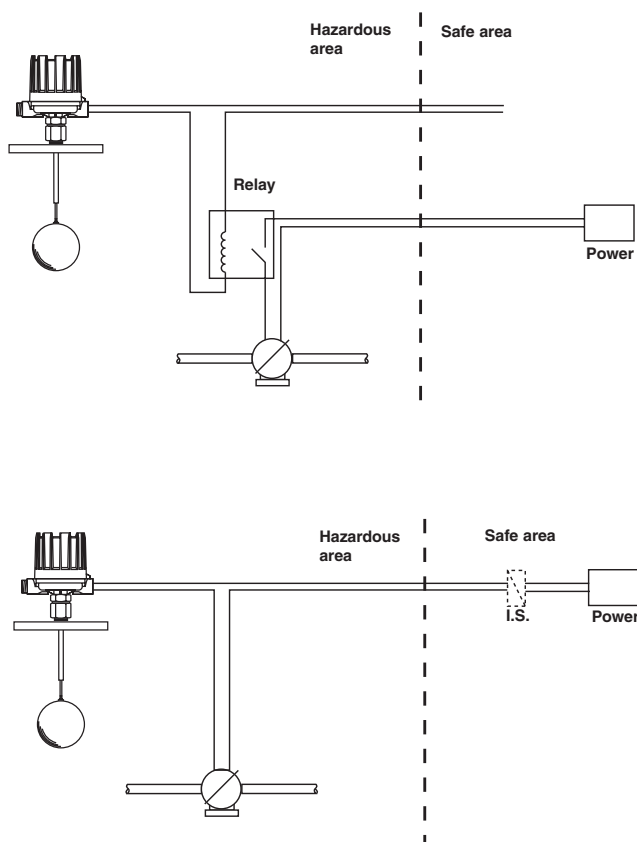

DIMENSIONS IN mm (inches)

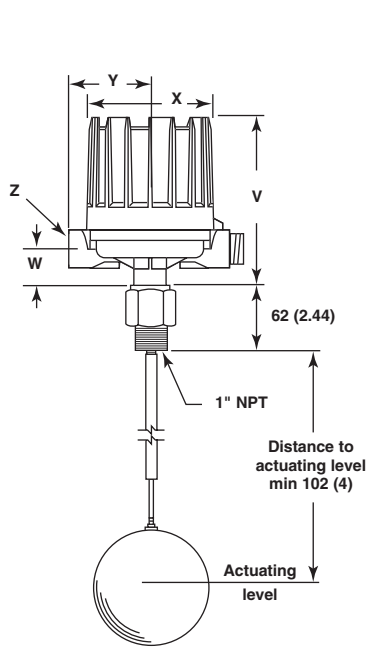

Model T20 with 1" NPT

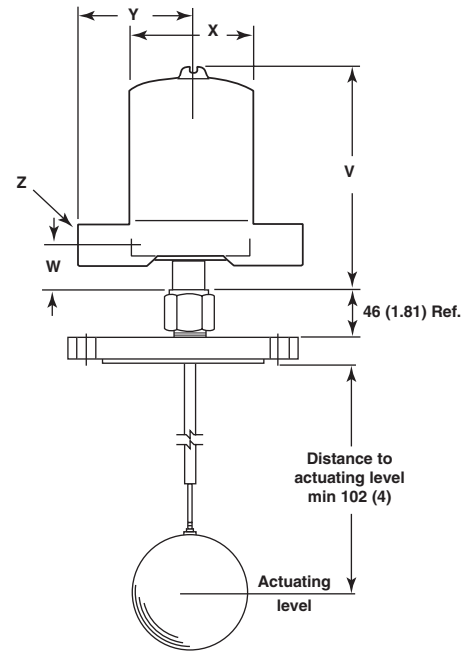

Model T20 with flange

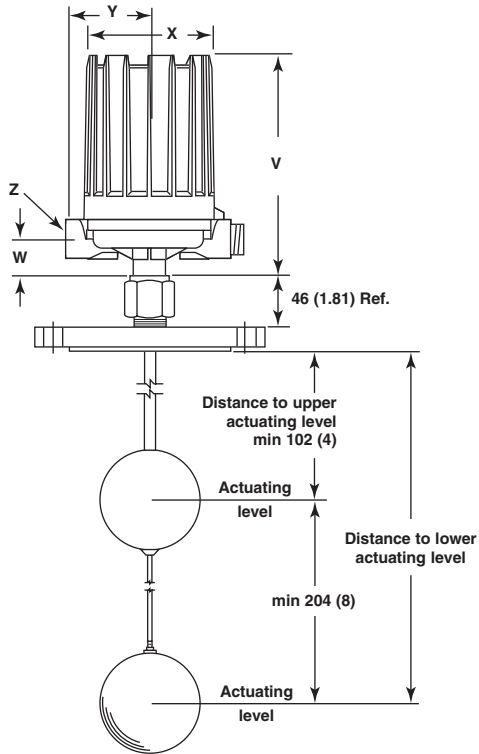

Model T21 with flange

	Distance to	Maximum	Minimum
	Upper level	1016 mm (40")	102 (4")
	Lower level	1219 mm (48")	305 (12")

Note: On model T21, the lower float actuates the upper switch mechanism. The upper float actuates the lower switch mechanism.

Housing type	Models	V		W		ø X		Y		Z
		mm	inches	mm	inches	mm	inches	mm	inches	
Weatherproof-FM (NEMA 7/9) - ATEX (Cast Alu)	T21 and T20 with HS-switch	257	10.12	42	1.66	151	5.93	109	4.29	M20 x 1,5 (*) or 1" NPT (2 entries - 1 plugged) (*) not for FM (NEMA 7/9)
	T20 excl. HS-switch	202	7.94							
CENELEC (Cast Iron)	All	249	9.80	45	1.77	143	5.63	110	4.33	M20 x 1,5 or 3/4" NPT (single entry - 2 entries at request)
Pneumatics Switch Module J	All	165	6.50	39	1.54	118	4.65	110	4.33	1/4" NPT
Pneumatics Switch Module K								130	5.12	

Allow 200 mm (7.87") overhead clearance / All housings are 360 ° rotatable



QUALITY ASSURANCE - ISO 9001

THE QUALITY ASSURANCE SYSTEM IN PLACE AT MAGNETROL GUARANTEES THE HIGHEST LEVEL OF QUALITY DURING THE DESIGN, THE CONSTRUCTION AND THE SERVICE OF CONTROLS. OUR QUALITY ASSURANCE SYSTEM IS APPROVED AND CERTIFIED TO **ISO 9001** AND OUR TOTAL COMPANY IS COMMITTED TO PROVIDING FULL CUSTOMER SATISFACTION BOTH IN QUALITY PRODUCTS AND QUALITY SERVICE.

PRODUCT WARRANTY

ALL MAGNETROL MECHANICAL LEVEL CONTROLS ARE WARRANTED FREE OF DEFECTS IN MATERIALS AND WORKMANSHIP FOR FIVE FULL YEARS FROM THE DATE OF ORIGINAL FACTORY SHIPMENT.

IF RETURNED WITHIN THE WARRANTY PERIOD; AND, UPON FACTORY INSPECTION OF THE CONTROL, THE CAUSE OF THE CLAIM IS DETERMINED TO BE COVERED UNDER THE WARRANTY; THEN, MAGNETROL INTERNATIONAL WILL REPAIR OR REPLACE THE CONTROL AT NO COST TO THE PURCHASER (OR OWNER) OTHER THAN TRANSPORTATION.

MAGNETROL SHALL NOT BE LIABLE FOR MISAPPLICATION, LABOR CLAIMS, DIRECT OR CONSEQUENTIAL DAMAGE OR EXPENSE ARISING FROM THE INSTALLATION OR USE OF THE EQUIPMENT. THERE ARE NO OTHER WARRANTIES EXPRESSED OR IMPLIED, EXCEPT, SPECIAL WRITTEN WARRANTIES COVERING SOME MAGNETROL PRODUCTS.



UNDER RESERVE OF MODIFICATIONS

BULLETIN N°: BE 44-117.6
EFFECTIVE: MARCH 2002
SUPERSEDES: January 1996

BENELUX	Heikensstraat 6, 9240 Zele, België Tel. +32 (0)52.45.11.11 • Fax. +32 (0)52.45.09.93 • E-Mail: info@magnetrol.be
DEUTSCHLAND	Schloßstraße 76, D-51429 Bergisch Gladbach-Bensberg Tel. 02204 / 9536-0 • Fax. 02204 / 9536-53 • E-Mail: vertrieb@magnetrol.de
FRANCE	Le Vinci 6 - Parc d'activités de Mitry Compans, 1, rue Becquerel, 77290 Mitry Mory Tél. 01.60.93.99.50 • Fax. 01.60.93.99.51 • E-Mail: magnetrolfrance@magnetrol.fr
ITALIA	Via Arese 12, I-20159 Milano Tel. (02) 607.22.98 (R.A.) • Fax. (02) 668.66.52 • E-Mail: mit.gen@magnetrol.it
UNITED KINGDOM	Unit 1 Regent Business Centre, Jubilee Road Burgess Hill West Sussex RH 15 9TL Tel. (01444) 871313 • Fax (01444) 871317 • E-Mail: sales@magnetrol.co.uk
INDIA	B4/115 Safdurjung Enclave, New Delhi 110 029 Tel. 91 (11) 6186211 • Fax 91 (11) 6186418 • E-Mail: magnetrol@vsnl.com

www.magnetrol.com

OUR NEAREST REPRESENTATIVE

Wesmar

Hugo Tillquist AB Tel: 08-544 715 50
Wesmar Fax: 08-544 715 60
Box 1120 info@wesmar.se
164 22 Kista www.wesmar.se