

## DESCRIPTION

Thermatel TD1/TD2 switches can easily be adjusted to detect flow (gases and liquids), level or liquid-liquid interface. The TD1 is a 24 V DC line powered unit with integral electronics and a built-in DPDT relay. The TD2 is either V DC or V AC line powered, has integral or remote electronics and offers additionally LED indication, time delay and mA output for diagnostics and trending.

With continuous diagnostics, automatic temperature compensation, narrow hysteresis and fast response time, TD1/TD2 bring you the latest in thermal dispersion technology.

## FEATURES

- Easy field calibration – pre-calibration from factory at request.
- Variable flow or Flow/No flow detection of gases and liquids.
- Excellent low flow sensitivity.
- Automatic temperature compensation for repeatable alarm under varying process temperatures.
- Continuous diagnostics (sensor/electronics).
- Continuous monitoring of flow rate versus setpoint via LED (TD2).
- mA output provides repeatable indication of flow rate and fault detection (TD2).
- Flow can be measured over test points (TD2).
- Optional retractable fitting for dismantling under process conditions.
- Process conditions up to +450 °C (+850 °F) and 413 bar (6000 psig).
- Integral or remote electronics up to 150 m (500 ft).
- Suited for SIL1 and SIL2 loops (full FMEDA report available).



## APPLICATIONS

**Media:** all types of gases and liquids.

**Vessels:** pipesizes down to 1/4". Max sensor length up to 3,3 m. Can be installed at any angle vertically/horizontally – flanged, threaded or with compression fitting with or without hot or cold tap – ask for bulletin 41-103.

**Conditions:** Can be used on conductive and non conductive media, very light density to heavy viscous media (up to 10.000 cP). Can be set to ignore foam, aeration, turbulence, and cavitation.

## For FLOW/LEVEL/INTERFACE applications

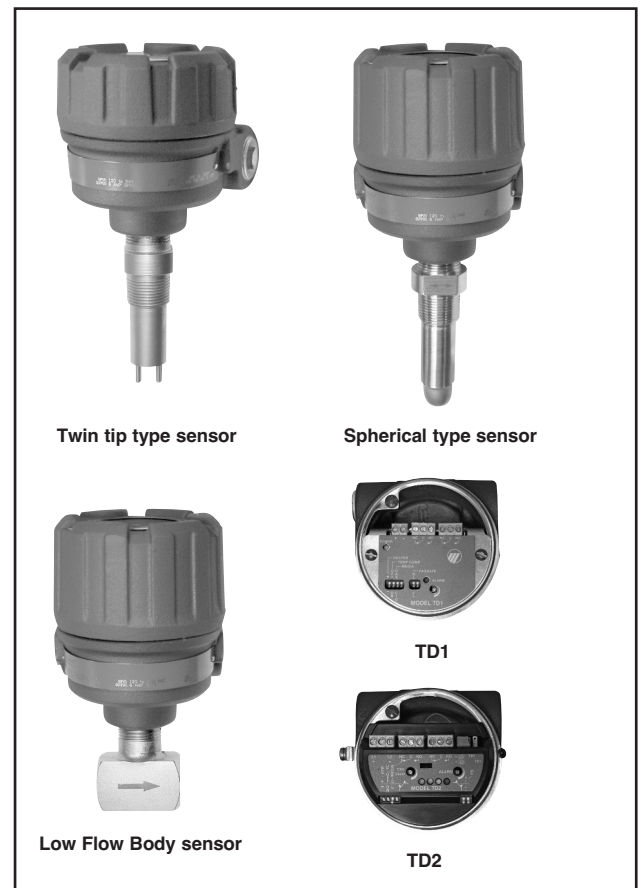

## AGENCY APPROVALS<sup>①</sup>

Model	Approval
TD1	II 1/2 G EEx d +ib, d [ib] IIC T4/T5, explosion proof (zone 0 & 1) With intrinsically safe probe circuitry valid for all sensors and outputs
TD2	II 2 G EEx d IIC T5, explosion proof (zone 1) For all sensors and outputs
	II 1/2 G EEx d IIC T5, explosion proof (zone 0) Only for sensors with 1 mm wall thickness and valid for hermetically sealed relay option
	II 1/2 G EEx d +ib, d [ib] IIC T4/T5, explosion proof (zone 0 & 1) With intrinsically safe probe circuitry valid for all sensors, not valid for hermetically sealed relay option
CSA/FM <sup>②</sup>	Non incandive / explosion proof

<sup>①</sup> For ATEX intrinsically safe units – Ask for bulletin 54-105.

<sup>②</sup> Consult factory for proper partnumber.

## PRINCIPLE OF OPERATION

The Thermatel electronics are either integral (TD1/TD2) or remote mounted (TD2) away from the sensor.

The sensing assembly contains 2 miniature RTD (Resistance Temperature Detector) tightly encased within a 316L stainless steel, Hastelloy C or Monel tube.

The first RTD (unheated) provides a reference temperature of the process conditions over the entire operating range of -70 °C to +200 °C (-100 °F to +400 °F).

High temperature design is suitable for temperatures ranging from -70 °C to +450 °C (-100 °F to +850 °F).

The second RTD is internally heated to establish a temperature differential above the process temperature. The cooling effect on the heated RTD, caused by the presence of flow or level, decreases the differential temperature between the two RTD's. The change in differential temperature is then converted to the actuation of the alarm/control relay and non-linear mA output (TD2).

### Flow

#### No Flow/Low Flow

In the absence of flow/low flow, the self-heated sensor creates a temperature differential between the two sensors.

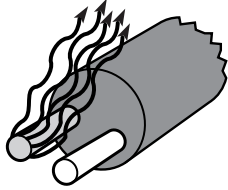
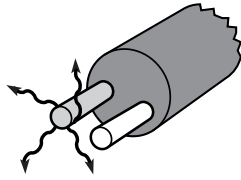

**Flow**  
As media flow increases across the sensing assembly, heat is dissipated and temperature differential decreases .

### Level

#### Low Level

In the absence of media, the self-heated sensor tip creates a temperature differential between the two sensors.

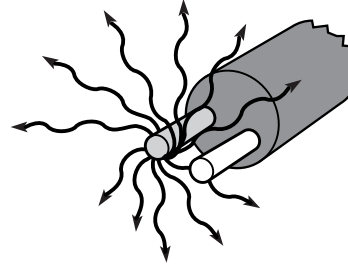
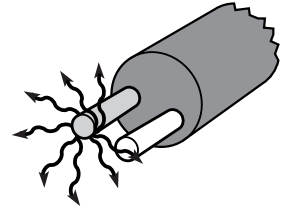

**High Level**  
As media contacts the sensing assembly, heat is absorbed by the fluid, decreasing the temperature differential.

## TEMPERATURE COMPENSATION

The alarm point of thermal dispersion switches has previously been affected by changing temperatures. With the TD1/TD2, the effect of changing process temperature has been greatly reduced.

### No temperature compensation

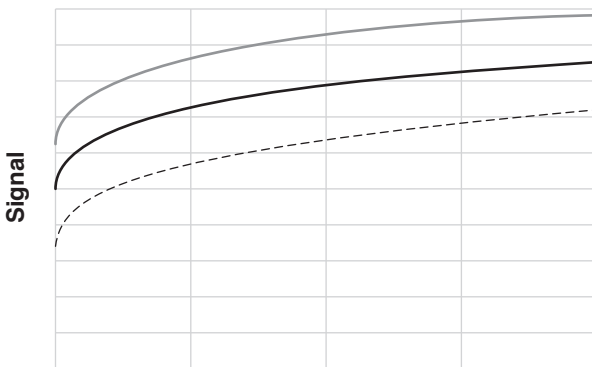

flow

### With temperature compensation

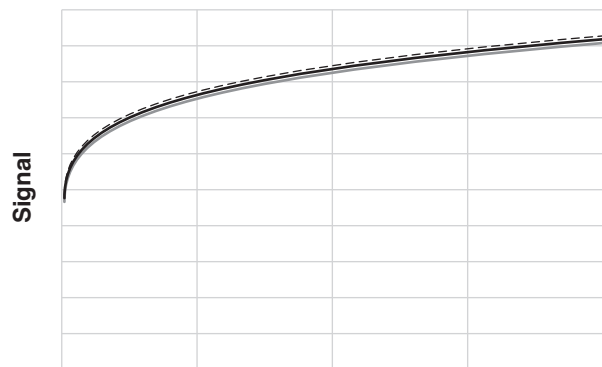

flow

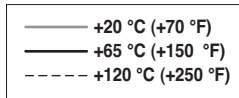

## FLOW BEHAVIOUR

### Typical air flow

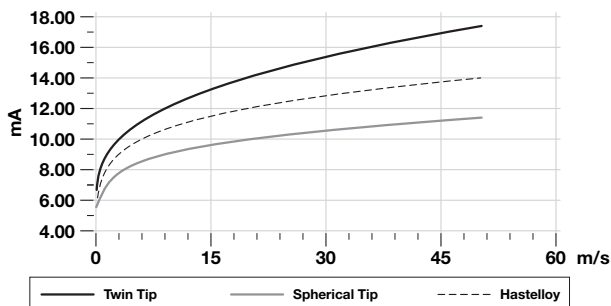

### Typical water flow

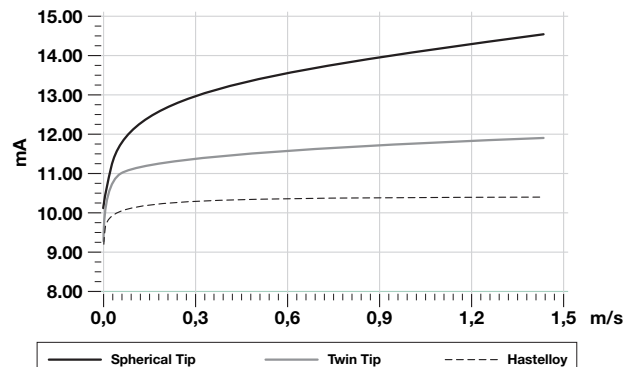

# APPLICATIONS

## APPLICATIONS FLOW

Thermatel® TD1/TD2 switches may be installed in a variety of flow applications as shown in the illustration below. Flow/No Flow can be detected in an input line to a primary tank, or in an output line. They may be installed for overflow detection in a pipe connected to an overflow tank or installed in a drain line for Wet/Dry indication. In addition, due to the capability to detect liquids or gases, the Thermatel® flow switch may be installed in a gas vent to detect off-gas from the primary tank.

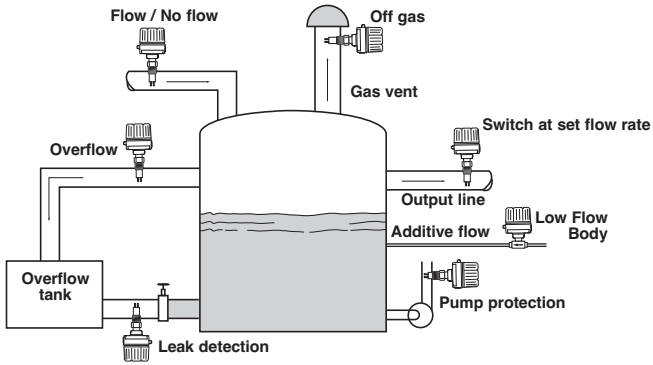

- Liquid or Gas flow detection
- Maintain a minimum flow rate
  - Pump protection
  - Cooling air/water
  - Lubrication systems
  - Chemical feed pumps
- Detect presence of flow
  - Relief valves
  - Flare lines

## APPLICATIONS LEVEL

Thermatel® series TD1/TD2 switches can be installed in a variety of level applications as shown in the illustration below. High or low level alarm applications can be installed in either vertical or horizontal mountings.

Sensors are available in lengths from 50 to 3300 mm (2" to 130") for a wide variety of applications.

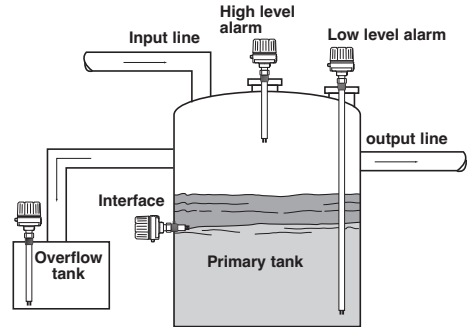

- High level
- Low level
- Interface between different liquids
  - Oil/water
  - Liquid/foam
- Suitable for any liquid level detection including:
  - High viscosity
  - High solids content
  - Aeration
  - Foam
- Insensitive to dielectric, specific gravity, viscosity
- Sanitary applications

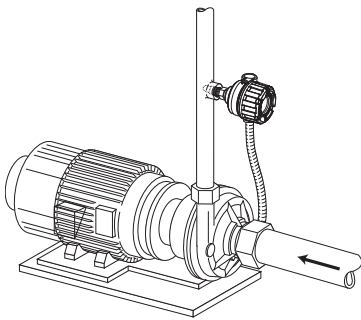

Pump Protection

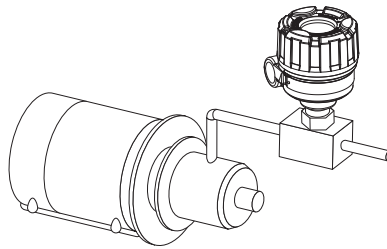

Chemical Feed Pump

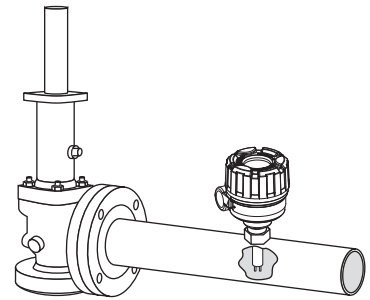

Relief Valve Monitoring

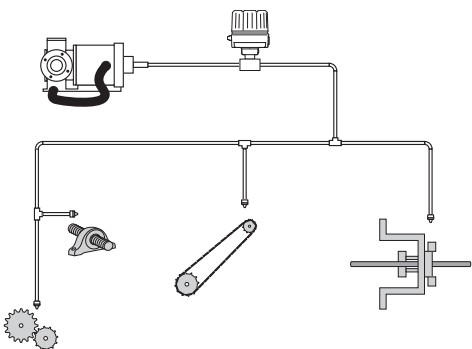

Lubrication Systems

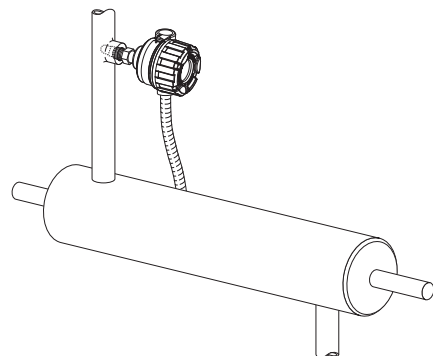

Cooling Water / Cooling Air

## EXPEDITE SHIP PLAN (ESP)

Several Thermatel switches are available for quick shipment, within max. 4 weeks after factory receipt of purchase order, through the Expedite Ship Plan (ESP).

Models covered by ESP service are conveniently colour coded in the selection data charts.

To take advantage of ESP, simply match the colour coded model number codes (standard dimensions apply).

ESP service may not apply to orders of ten units or more. Contact your local representative for lead times on larger volume orders, as well as other products and options.

## SELECTION DATA

**A complete Thermatel® system consists of:**

1. THERMATEL® electronics
2. Connecting cable (only applicable for remote mount TD2 units)
3. THERMATEL® sensor, incl. sensor housing (see pages 7, 9 and 10)
4. Optional: Mounting flanges (compatible with 3/4" threaded sensors)
5. Optional: Hot tap process connection, consult factory for details
6. Optional: Factory calibration, consult factory

## ELECTRONICS

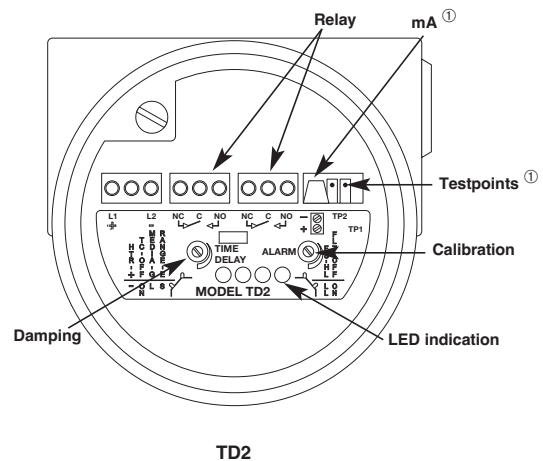
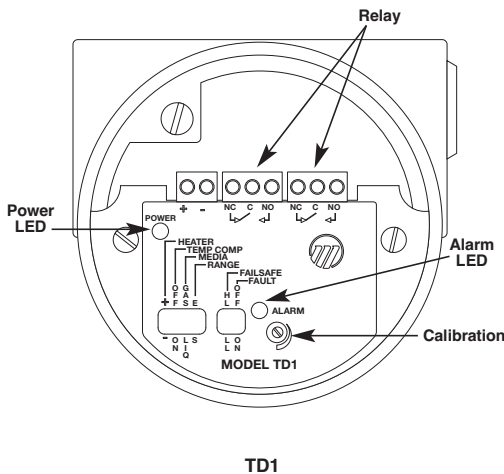

### TD1 main features:

#### Alarm/Fault indication:

Alarm relay de-energizes and red LED:

- turns on (alarm)
- blinks (fault).

#### Factory calibration:

TD1/TD2 can be delivered pre-calibrated at a fixed setpoint. TD2 can be delivered with a complete calibration curve, allowing the customer to field adjust the setpoint by using a voltmeter at the test points.

### TD2 features:

#### mA output

- for trending: the calibrated setpoint corresponds with a specific mA value but although not linear, it provides important process information. With increasing flow or immersed sensor, the mA signal increases.

- for diagnostics: either 3.6 mA (Low level/flow failsafe) or 22mA (High level/flow failsafe) output, indicates for an instrument failure (electronics/sensor/out of range).

#### Test points:

Allow the user to periodically check the setpoint and verify for set point drift. The setpoints read voltage units.

#### LED indication:

The LED's show progressively actual flow/level versus the calibrated setpoint

#### Remote electronics:

The sensor can be mounted away for 150 m (500') – the order code for the remote electronics housing is included in the amplifiers' ordering code.

Typical mA signals

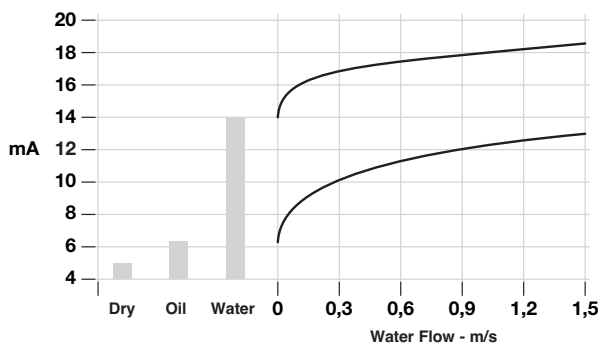

① not for all models - see amplifier part number on page 5

**1. Order code for Thermatel® TD1 electronics**

T D 1 - 2 D 0 0 - 0	Thermatel TD1 electronics, 24 V DC for flow, level and interface Integral mount electronics with 8 A DPDT relay
---------------------	--

Approvals

3	General purpose / FM-CSA explosion proof
C	ATEX explosion proof (zone 0 and 1)

Housing

0	IP66, Cast aluminium housing with 3/4" NPT entry (2 entries - one plugged)
1	IP66, Cast aluminium housing with M20 x 1,5 entry (2 entries - one plugged)

T	D	1	-	2	D	0	0	-	0		
---	---	---	---	---	---	---	---	---	---	--	--

**complete order code for Thermatel® TD1 electronics**

**1. Order code for Thermatel® TD2 electronics**

T D 2	Thermatel TD2 Electronics with continuous LED indication and mA output
-------	--

POWER

7	240 V AC (100-264 V AC)
8	24 V DC (± 20 %)

OUTPUT

D 0	8 A DPDT relay
H 0	1 A Hermetically sealed DPDT relay <sup>①</sup>

<sup>①</sup> requires for ATEX 1G / zone 0 applications a TMC/TMD/TMH sensor with 1 mm wall thickness

ACCESSORIES

0	Blind housing cover
1	Housing cover with glass window (for aluminium housings only)

MOUNTING CONFIGURATION

0	Integral electronics
1	Remote electronics

APPROVALS

3	General purpose / FM-CSA explosion proof
C	ATEX explosion proof - zone 0 <sup>①</sup> - with 8A DPDT relay: no mA available - with 1A HS DPDT relay: mA output only available in combination with TMC TMD or TMH sensors with 1 mm wall thickness – see page 7 and 9
G	ATEX explosion proof - zone 1

<sup>①</sup> Typically used for level and interface applications only.

Housing - General purpose

0	IP66, Cast Aluminium housing, 3/4" NPT cable entry (2 entries - one plugged)
1	IP66, Cast Aluminium housing, M20 x 1,5 cable entry (2 entries - one plugged)
2	IP66, Cast SST housing, 3/4" NPT cable entry (2 entries - one plugged)
3	IP66, Cast SST housing, M20 x 1,5 cable entry (2 entries - one plugged)

T	D	2									
---	---	---	--	--	--	--	--	--	--	--	--

**complete order code for Thermatel® TD2 electronics**

**2. Order code for connecting cable (6-wire cable/shielded - for general purpose). Consult factory for explosion proof cable.**

0 0 3 - 1 5 0	From 3 m (10') min. to 150 m (500') max. Specify in increments of 1 m (3.28')
---------------	---

0	3	7	-	3	1	9	8			
---	---	---	---	---	---	---	---	--	--	--

**complete order code for connecting cable**

## TWO SENSOR TIP DESIGNS

Thermatel offers two sensor tip designs: the sensor twin tip and the unique spherical tip. Both designs have similar operating ranges.



The spherical tip is recommended for all types of applications: general purpose, high viscosity and applications where buildup can occur.

Both sensors detect flow or level at approximately the same rate. However, the spherical tip responds faster to a loss of flow or a dry condition.

## PRESSURE/TEMPERATURE RATING

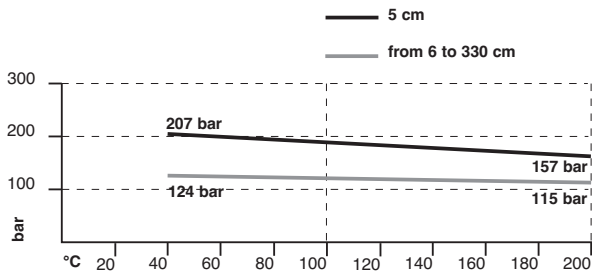

Standard Twin Tip Probe (TMC/TMD)

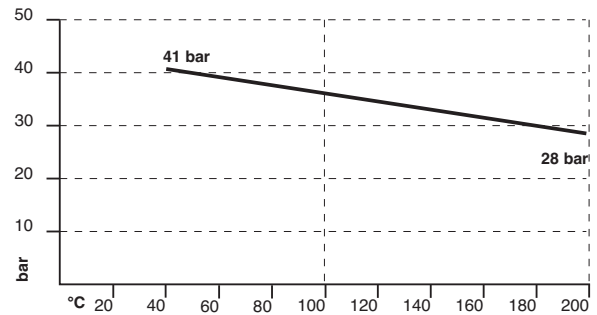

Standard Spherical Probe (TMA/TMB)

## DIMENSIONS IN MM (INCHES)

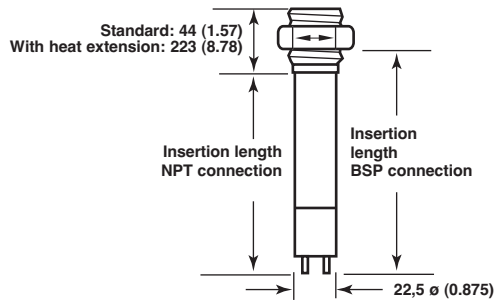

Threaded Sensor

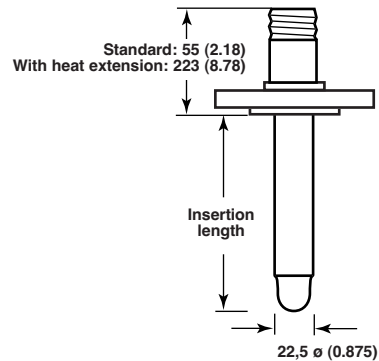

Flanged Sensor

## CONNECTIONS

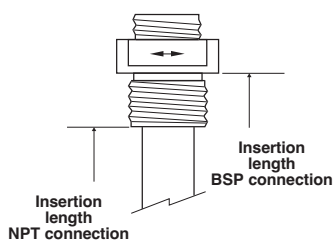

Threaded

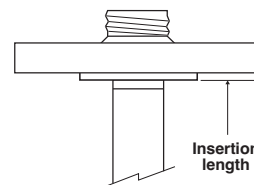

Welded flange ANSI - EN/DIN

# SELECTION DATA (CONT.)

## 3. Order code for Thermatel® TD1/TD2 – STANDARD SENSOR

### BASIC MODEL NUMBER – SENSOR

T M A	Standard spherical tip	max +120 °C (+250 °F) / max 41 bar ( 600 psi) <sup>①</sup>
T M B	Standard spherical tip - with heat extension	max +200 °C (+400 °F) / max 41 bar ( 600 psi)
T M C	Standard twin tip	max +120 °C (+250 °F) / max 207 bar (3000 psi) <sup>① ②</sup>
T M D	Standard twin tip - with heat extension	max +200 °C (+400 °F) / max 207 bar (3000 psi) <sup>②</sup>

① TMA/TMC sensors can handle process temperatures up to +200 °C (+400 °F) with remote electronics.  
 ② Max 127 bar (1850 psig) for sensors > min. length

### MATERIAL OF CONSTRUCTION FOR SENSOR AND PROCESS CONNECTION

A	316/316 L (1.4401/1.4404) stainless steel
B	Hastelloy C (2.4819) - only available for twin tip sensors (TMC/TMD) – 1 mm wall thickness
C	Monel (2.4360) - only available for twin tip sensors (TMC/TMD) – 1 mm wall thickness
D	316/316 L (1.4401/1.4404) stainless steel (TMC/TMD) – 1 mm wall thickness

### PROCESS CONNECTION SIZE

1	1	Threaded 3/4" NPT
2	1	Threaded 1" NPT
2	2	Threaded G1 (1" BSP)

### ANSI FLANGED

2	3	1"	150 lbs ANSI RF flange
2	4	1"	300 lbs ANSI RF flange
2	5	1"	600 lbs ANSI RF flange
3	3	1 1/2"	150 lbs ANSI RF flange
3	4	1 1/2"	300 lbs ANSI RF flange
3	5	1 1/2"	600 lbs ANSI RF flange
4	3	2"	150 lbs ANSI RF flange
4	4	2"	300 lbs ANSI RF flange
4	5	2"	600 lbs ANSI RF flange

### EN/DIN FLANGED

B	B	DN 25	PN 16/25/40	EN 1092-1	Type A
B	C	DN 25	PN 63/100	EN 1092-1	Type B2
C	B	DN 40	PN 16/25/40	EN 1092-1	Type A
C	C	DN 40	PN 63/100	EN 1092-1	Type B2
D	A	DN 50	PN 16	EN 1092-1	Type A
D	B	DN 50	PN 25/40	EN 1092-1	Type A
D	D	DN 50	PN 63	EN 1092-1	Type B2
D	E	DN 50	PN 100	EN 1092-1	Type B2

### INSERTION LENGTH – SPECIFY FOR INCREMENTS OF 10 mm (0.39")

0	0	5	Minimum length 50 mm (2")
0	0	8	Minimum length 80 mm (3") – sensors with BSP (G1) connection
3	3	0	Maximum length 3300 mm (130")

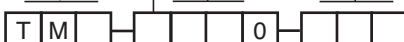

complete order code for TD1/TD2 Thermatel® STANDARD SENSOR

## DIMENSIONS IN MM (INCHES) – TMH



High Temperature Sensor (TMH)

## PRESSURE/TEMPERATURE RATING – TMH

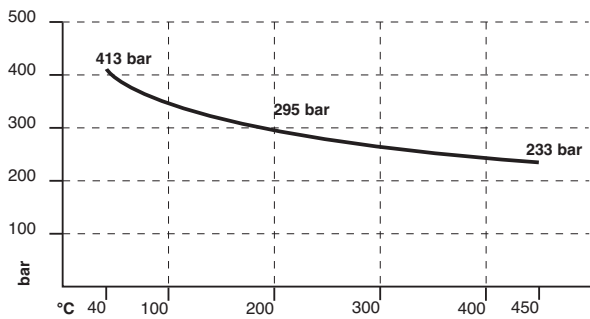

## DIMENSIONS IN MM (INCHES) – TML

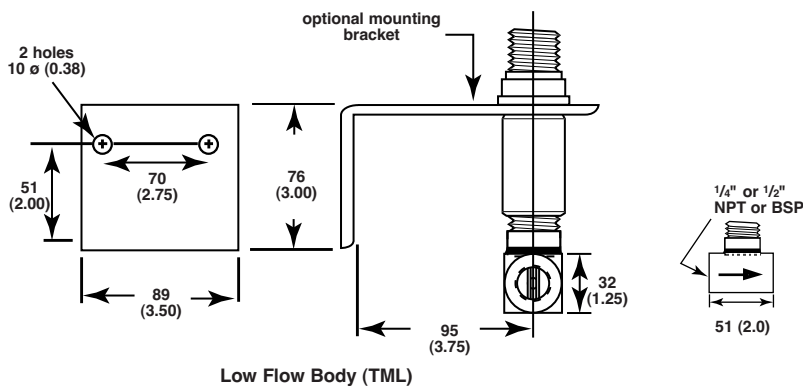

Low Flow Body (TML)

## PRESSURE/TEMPERATURE – TML

Max 285 bar (4100 psi) @ max +120 °C (+250 °F) with integral electronics / +200 °C (+400 °C) with remote electronics.  
 Max 400 bar (5800 psi) @ +40 °C (100 °F).

## RECOMMENDED FLOW RANGES

Size	Water	Air
1/4" flow body	0,02 to 5,7 l/h (0.0055 GPH to 1.5 GPH)	0,006 Nm³/h to 5,75 Nm³/h (100 sccm to 200 SCFH)
1/2" flow body	0,04 to 11,5 l/h (0.01 GPH to 3 GPH)	0,015 Nm³/h to 11,5 Nm³/h (250 sccm to 400 SCFH)

SELECTION DATA (CONT.)

3. Order code for Thermatel® TD1/TD2 – HIGH TEMPERATURE / HIGH PRESSURE SENSOR

T M H	High temperature / high pressure twin tip – max 450 °C (850 °F) / max 413 bar (6000 psi)
-------	--

MATERIAL OF CONSTRUCTION FOR SENSOR AND PROCESS CONNECTION

A	316/316 L (1.4401/1.4404) stainless steel
B	Hastelloy C (2.4819) – 1 mm wall thickness
D	316/316 L (1.4401/1.4404) stainless steel – 1 mm wall thickness

PROCESS CONNECTION SIZE

1	1	Threaded 3/4" NPT
2	1	Threaded 1" NPT
2	2	Threaded G1 (1" BSP)

ANSI FLANGED

2	3	1"	150 lbs ANSI RF flange
2	4	1"	300 lbs ANSI RF flange
2	5	1"	600 lbs ANSI RF flange
2	7	1"	900/1500 lbs ANSI RF flange
3	3	1 1/2"	150 lbs ANSI RF flange
3	4	1 1/2"	300 lbs ANSI RF flange
3	5	1 1/2"	600 lbs ANSI RF flange
3	7	1 1/2"	900/1500 lbs ANSI RF flange
3	8	1 1/2"	2500 lbs ANSI RF flange
4	3	2"	150 lbs ANSI RF flange
4	4	2"	300 lbs ANSI RF flange
4	5	2"	600 lbs ANSI RF flange
4	7	2"	900/1500 lbs ANSI RF flange
4	8	2"	2500 lbs ANSI RF flange

EN/DIN FLANGED

B	B	DN 25	PN 16/25/40	EN 1092-1 Type A
B	C	DN 25	PN 63/100	EN 1092-1 Type B2
B	G	DN 25	PN 250	EN 1092-1 Type B2
C	B	DN 40	PN 16/25/40	EN 1092-1 Type A
C	C	DN 40	PN 63/100	EN 1092-1 Type B2
C	G	DN 40	PN 250	EN 1092-1 Type B2
C	J	DN 40	PN 400	EN 1092-1 Type B2
D	A	DN 50	PN 16	EN 1092-1 Type A
D	B	DN 50	PN 25/40	EN 1092-1 Type A
D	D	DN 50	PN 63	EN 1092-1 Type B2
D	E	DN 50	PN 100	EN 1092-1 Type B2
D	G	DN 50	PN 250	EN 1092-1 Type B2
D	J	DN 50	PN 400	EN 1092-1 Type B2

INSERTION LENGTH – SPECIFY FOR INCREMENTS OF 10 mm (0.39")

0	0	5	Minimum length 50 mm (2")
0	0	8	Minimum length 80 mm (3") – sensors with BSP (G1) connection
0	9	0	Maximum length 900 mm (35.4")

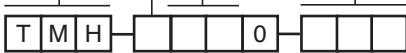

complete order code for TD1/TD2 Thermatel® HIGH TEMPERATURE /HIGH PRESSURE SENSOR

3. Order code for Thermatel® TD1/TD2 – LOW FLOW BODY SENSOR

T M L	Low flow body – max +120 °C (+250 °F) / max 400 bar (5800 psi) – integral electronics – max +200 °C (+400 °F) / max 400 bar (5800 psi) – remote electronics
-------	--

MATERIAL OF CONSTRUCTION FOR SENSOR AND PROCESS CONNECTION

A	316/316 L (1.4401/1.4404) stainless steel
---	---

PROCESS CONNECTION SIZE

T	1	Threaded 1/4" NPT
V	1	Threaded 1/2" NPT
T	0	Threaded G 1/4 (1/4" BSP)
V	0	Threaded G 1/2 (1/2" BSP)

MOUNTING BRACKET

0	0	0	None
1	0	0	With carbon steel mounting bracket



complete order code for TD1/TD2 Thermatel® LOW FLOW BODY SENSOR

## SELECTION DATA (CONT.)

### 3. Order code for Thermatel® TD1/TD2 – MINI SENSOR

T M M	Mini twin tip (16 mm diam.) – max +120 °C (+250 °F) / max 207 bar (3000 psi) for standard sensor length max +120 °C (+250 °F) / max 127 bar (1850 psi) for other sensor lengths. max +200 °C (+400 °F) with remote electronics
-------	--

#### MATERIAL OF CONSTRUCTION FOR SENSOR AND PROCESS CONNECTION

A	316/316 L (1.4401/1.4404) stainless steel
---	---

#### PROCESS CONNECTION SIZE

0	1	Threaded 1/2" NPT
1	1	Threaded 3/4" NPT
2	1	Threaded 1" NPT

#### INSERTION LENGTH – SPECIFY FOR INCREMENTS OF 10 mm (0.39")

0	0	3	Standard length 25 mm (1")
0	0	5	Minimum selectable length 50 mm (2")
3	3	0	Maximum selectable length 3300 mm (130")

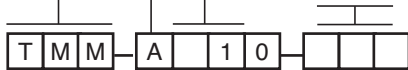

complete order code TD1/TD2 Thermatel® MINI SENSOR

### DIMENSIONS IN MM (INCHES)

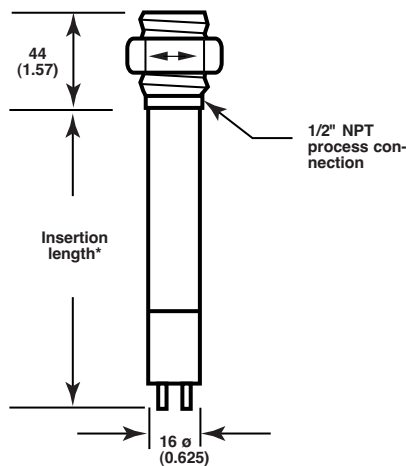

Mini Sensor (TMM)

### PRESSURE/TEMPERATURE RATING

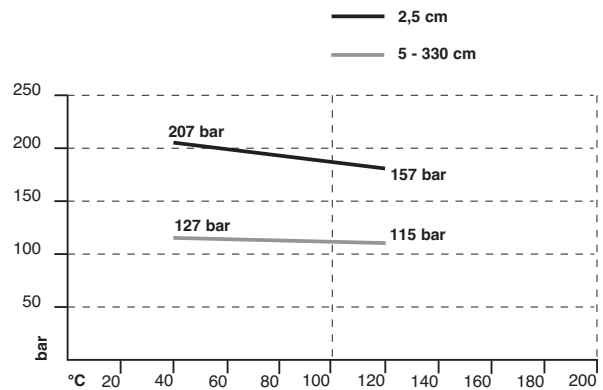

### RECOMMENDED FLOW RANGES

Size	Water	Air
1/2" "T"	0,75 to 680 l/h (0.2 GPH to 180 GPH)	0,85 to 120 Nm <sup>3</sup> /h (0.5 to 70 SCFM)
3/4" "T"	2 to 900 l/h (0.5 GPH to 240 GPH)	2,5 to 170 Nm <sup>3</sup> /h (1.5 to 100 SCFM)
1" "T"	3,8 to 1600 l/h (1 GPH to 420 GPH)	5 to 290 Nm <sup>3</sup> /h (3 to 170 SCFM)

## ELECTRONICS SPECIFICATIONS

<b>Description</b>		<b>TD1</b>	<b>TD2</b>
Power at terminals		19.2 to 28.8 V DC	19.2 to 28.8 V DC 100 to 264 V AC, 50-60 Hz
Power consumption		3,5 W @ 24 V DC	4 W @ 24 V DC or 5 W @ 264 V DC
Flow range		Standard sensors: HTHP, Hastelloy C / Monel: (1 mm wall sensors) 1/4" Low flow body: 1/2" Low flow body:	0,003 to 1,5 m/s (0.01 to 5.0 FPS) – water 0,03 to 150 m/s (0.1 to 500 FPS) – air 0,003 to 0,3 m/s (0.01 to 1.0 FPS) – water 0,03 to 150 m/s (0.1 to 500 FPS) – air 0,02 to 5,7 l/h – water and min 0,006 Nm <sup>3</sup> /h – air/gases 0,04 to 11,5 l/h – water and min 0,015 Nm <sup>3</sup> /h – air/gases
Signal output	Alarm	8 A DPDT relay @ 30 V DC	8 A DPDT relay @ 30 V DC / 250 V AC 1 A HS DPDT relay @ 28 V DC
	Continuous	Not applicable	non linear mA for trending (not for all models - see amplifier part number on page 5)
	Error	Via alarm relay	3.6 mA (Low FS) – 22 mA (High FS) and alarm relay
Damping		Not available	0 to 100 s (in addition to sensor response)
User interface		Local switches for gain setting, function setting and Hi/Lo failsafe Calibration and damping via potentiometer	
Display		LED's for Power/Alarm status	2 green LED's (safe condition), 1 yellow LED (alarm setpoint being approached) 1 red LED (alarm condition)
Approvals		II 2 G EEx d IIC T5, explosion proof - TD2 for zone 1 II 1/2 G EEx d +ib, d [ib] IIC T4/T5, explosion proof - TD1 & TD2 - TD1 for all sensors and outputs for zone 1 & 0 - TD2 with 1mm wall thickness sensor/ 8A DPDT relay for zone 0 II 1/2 G EEx d IIC T5, explosion proof - TD2 with 1mm wall thickness sensor/ Hermetically sealed relay for zone 0	
SIL (Safety Integrity Level)		Functional safety to SIL1 as 1oo1 / SIL2 as 1oo2 in accordance to IEC 61508 – SFF of 69,3 % (TD1) and 73 % (TD2) – full FMEDA reports and declaration sheets available	
Housing materials		IP66, Cast aluminium epoxy coated or cast stainless steel	
Net and gross weight		2 kg (4.6 lbs) with 50 mm (2") sensor	

## PERFORMANCE

<b>Description</b>	<b>Specification</b>
Response time	1-10 s typical (dependant on sensor type, application and set point)
Repeatability	< 1 % @ constant °C
Ambient temperature	ATEX EEx d - T4 & non Ex: -40 °C up to +70 °C (-40 °F to +160 °F) ATEX EEx d - T5: -40 °C to +40 °C (-40 °F to +105 °F) Storage: -50 °C to +75 °C (-58 °F to +170 °F)
Humidity	0-99 % non condensing
Electromagnetic compatibility	Meets CE requirements (EN 61000-6-4, EN 61000-6-2) and Namur NE 21

## SENSOR SPECIFICATIONS

<b>Description</b>	<b>Twin tip - spherical sensors TMM - TMA/TMB - TMC/TMD</b>	<b>HTHP sensor TMH</b>	<b>Low flow body TML</b>
Materials	316/316L (1.4401/1.4404) Hastelloy C (2.4819) – TMC/TMD Monel (2.4360) – TMC/TMD	316/316L (1.4401/1.4404) Hastelloy C (2.4819)	316/316L (1.4401/1.4404)
Sensor / pipe diameter	22,5 mm (0.87") – except TMM 16 mm (0.63") – TMM	22,5 mm (0.87")	1/4" or 1/2"
Process connection	Threaded: 1/2" NPT (TMM), 3/4" NPT, 1" NPT, G1 (1" BSP) Flanged: ANSI, EN/DIN		F- 1/4" or 1/2" NPT or BSP
Probe length	5 - 330 cm (2" - 130") 2,5 - 150 cm (1" - 60") – TMM	5 to 90 cm (2-36")	Not applicable
Max process temperature <sup>①</sup>	TMA/TMC/TMM: -70 to +120 °C (-100 to 250 °F) TMB/TMD: -70 to +200 °C (-100 to 400 °F)	-70 °C to +450 °C (-100 °F to +850 °F)	-70 °C to +120 °C (-100 °F to +250 °F)
Max process pressure	TMA/TMB: 41 bar (600 psi) TMC/TMD: 207 bar (3000 psi) <sup>②</sup> TMM: 207 bar (3000 psi) <sup>②</sup>	413 bar (6000 psi)	400 bar (5800 psi)
Recommended for	TMA: best sensitivity for liquid flows / suitable for gas flow – resists heavy coating TMB: same as TMA but can be used with integral electronics up to +200 °C (+400 °F) TMC: best sensitivity for air/gas flows – resists light coating TMD: same as TMC but can be used with integral electronics up to 200 °C (+400 °F) TMM: for direct mounting in "T" pieces on small pipe sizes – light coating TMH: high temperature and pressure conditions – light coating TML: for the detection, control of extreme low flows, resists light coating		

<sup>①</sup> Use remote electronics (TD2) for temperatures > +120 °C (+250 °F) up to max +200 °C (+400 °F) or sensors with heat extension (TMB/TMD) when using integral electronics.

<sup>②</sup> Max 127 bar (1850 psig) for sensors > minimum length.

# DIMENSIONS IN MM (INCHES)

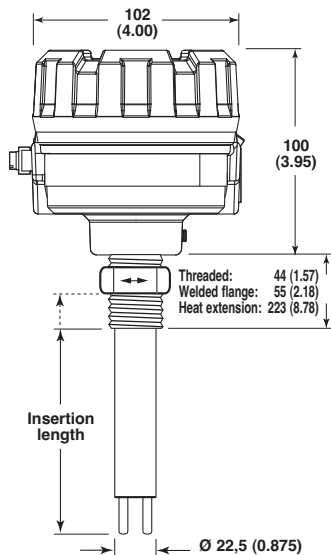

Model TD1 with TMC Twin Tip Sensor

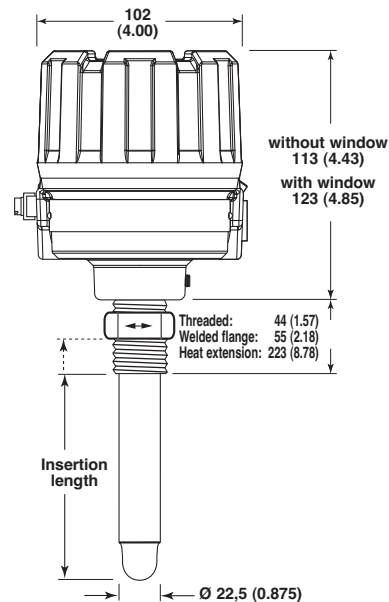

Model TD2  
Integral electronics  
with TMA Spherical Tip Sensor

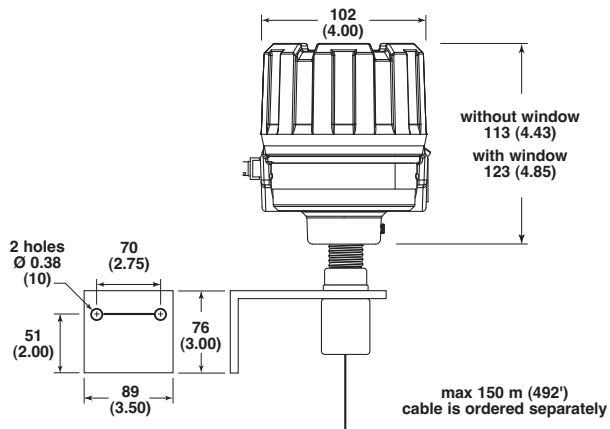

Model TD2 with Remote electronics

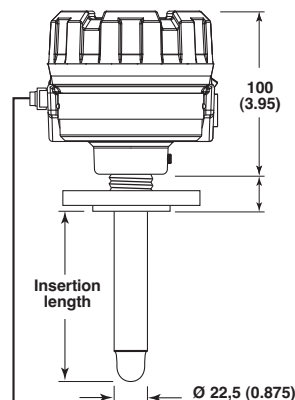

Remote TMA Spherical Tip Probe  
with Flange Connection

## QUALITY ASSURANCE - ISO 9001:2000



THE QUALITY ASSURANCE SYSTEM IN PLACE AT MAGNETROL GUARANTEES THE HIGHEST LEVEL OF QUALITY DURING THE DESIGN, THE CONSTRUCTION AND THE SERVICE OF CONTROLS. OUR QUALITY ASSURANCE SYSTEM IS APPROVED AND CERTIFIED TO ISO 9001:2000 AND OUR TOTAL COMPANY IS COMMITTED TO PROVIDING FULL CUSTOMER SATISFACTION BOTH IN QUALITY PRODUCTS AND QUALITY SERVICE.

## PRODUCT WARRANTY

ALL MAGNETROL ELECTRONIC AND ULTRASONIC LEVEL CONTROLS ARE WARRANTED FREE OF DEFECTS IN MATERIALS AND WORKMANSHIP FOR ONE FULL YEAR FROM THE DATE OF ORIGINAL FACTORY SHIPMENT. IF RETURNED WITHIN THE WARRANTY PERIOD; AND, UPON FACTORY INSPECTION OF THE CONTROL, THE CAUSE OF THE CLAIM IS DETERMINED TO BE COVERED UNDER THE WARRANTY; THEN, MAGNETROL INTERNATIONAL WILL REPAIR OR REPLACE THE CONTROL AT NO COST TO THE PURCHASER (OR OWNER) OTHER THAN TRANSPORTATION. MAGNETROL SHALL NOT BE LIABLE FOR MISAPPLICATION, LABOR CLAIMS, DIRECT OR CONSEQUENTIAL DAMAGE OR EXPENSE ARISING FROM THE INSTALLATION OR USE OF THE EQUIPMENT. THERE ARE NO OTHER WARRANTIES EXPRESSED OR IMPLIED, EXCEPT, SPECIAL WRITTEN WARRANTIES COVERING SOME MAGNETROL PRODUCTS.



BULLETIN N°:  
EFFECTIVE:  
SUPERSEDES:

BE 54-110.3  
JULY 2008  
April 2008

UNDER RESERVE OF MODIFICATIONS

BENELUX FRANCE	Heikensstraat 6, 9240 Zele, België -Belgique Tél. +32 (0)52.45.11.11 • Fax. +32 (0)52.45.09.93 • E-Mail: info@magnetrol.eu
DEUTSCHLAND	Alte Ziegelei 2-4, D-51491 Overath Tel. +49 (0)2204 / 9536-0 • Fax. +49 (0)2204 / 9536-53 • E-Mail: vertrieb@magnetrol.de
INDIA	C-20 Community Centre, Janakpuri, New Delhi - 110 0058 Tel. +91 (11) 41661840 • Fax +91 (11) 41661843 • E-Mail: info@magnetrolindia.com
ITALIA	Via Arese 12, I-20159 Milano Tel. +39 02 607.22.98 (R.A.) • Fax. +39 02 668.66.52 • E-Mail: mit.gen@magnetrol.it
U.A.E.	DAFZA Office 5EA 722 • PO Box 293671 • Dubai Tel. +971-4-6091735 • Fax +971-4-6091736 • E-Mail: info@magnetrol.ae
UNITED KINGDOM	Unit 1 Regent Business Centre, Jubilee Road Burgess Hill West Sussex RH 15 9TL Tel. +44 (0)1444 871313 • Fax +44 (0)1444 871317 • E-Mail: sales@magnetrol.co.uk

www.magnetrol.com

OUR NEAREST REPRESENTATIVE