

ECHOTEL® 961/962 LOOP POWERED

Installation and Operating Manual

Ultrasonic

Single and

Dual Point

Level Switches



Model 961



Model 962

UNPACKING

Unpack the instrument carefully. Make sure all components have been removed from the foam protection. Inspect all components for damage. Report any concealed damage to the carrier within 24 hours. Check the contents of the carton/crates against the packing slip and report any discrepancies to Magnetrol. Check the nameplate model number to be sure it agrees with the packing slip and purchase order. Check and record the serial number for future reference when ordering parts.



These units are in compliance with:

1. The EMC directive 2004/108/EC. The units have been tested to EN 61326: 1997 + A1 + A2.
2. Directive 94/9/EC for equipment or protective system intended for use in potentially explosive atmospheres. EC-type examination certificate number ISSeP06ATEX011X - intrinsically safe and ISSeP06ATEX008 - flameproof enclosure.
3. The PED Directive 97/23/EC (pressure equipment directive). Safety accessories per category IV module H1.

Nameplate:
- part number
- serial n°



SPECIAL CONDITIONS FOR ATEX INTRINSICALLY SAFE USE

Materials marked as Category 1 equipment and used in hazardous areas requiring this category, shall be installed in such a way that, even in the event of rare incidents, the aluminium enclosure cannot be an ignition source due to impact or friction.

MOUNTING

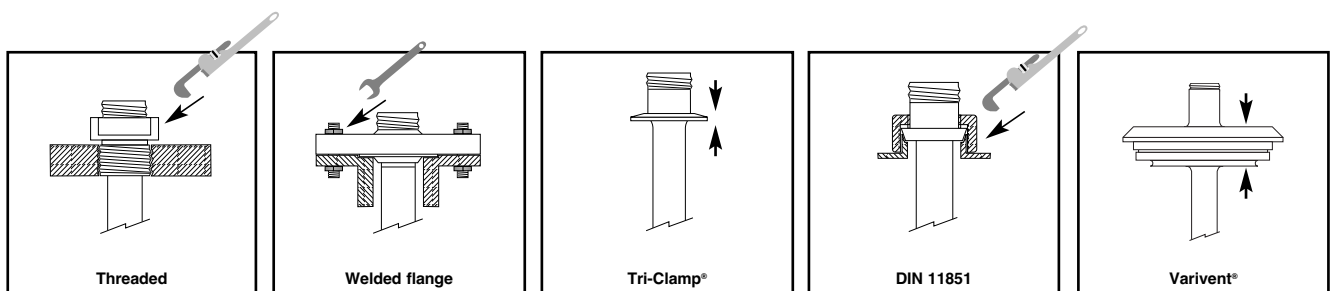
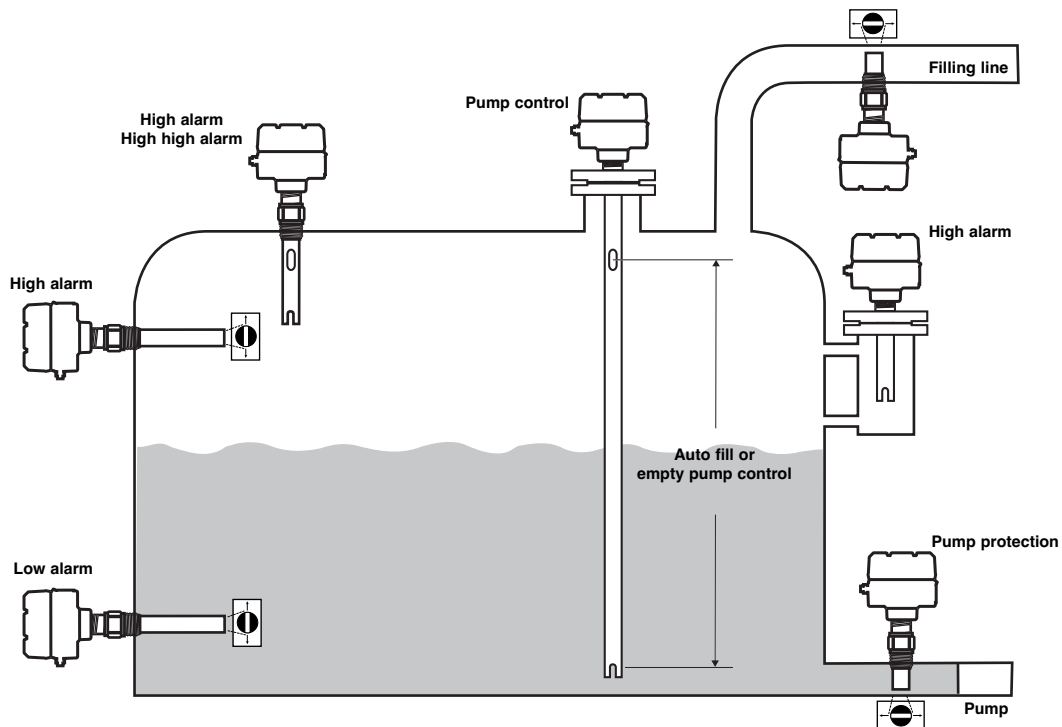

WIRING

Echotel® 961 electronics

Echotel® 962 electronics

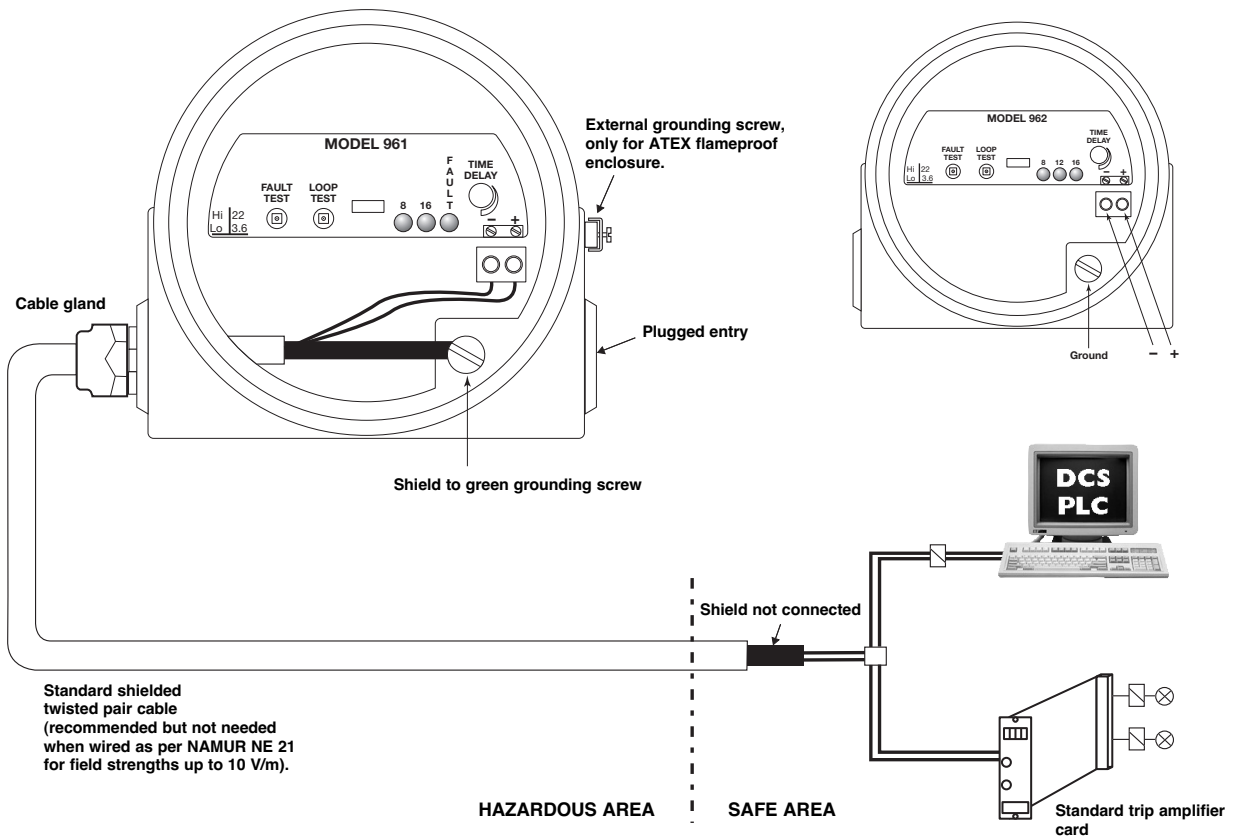

Important: Connect the unit to the ground for avoiding earth potential drifts.

USER INTERFACE

Echotel® 961

Echotel® 962

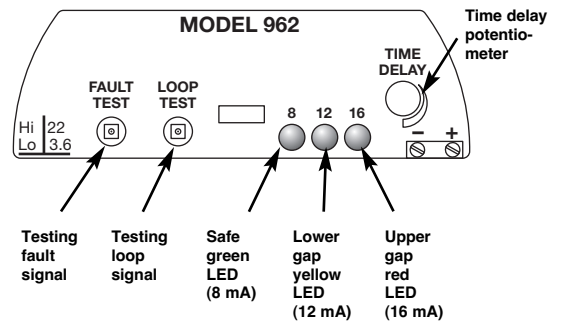
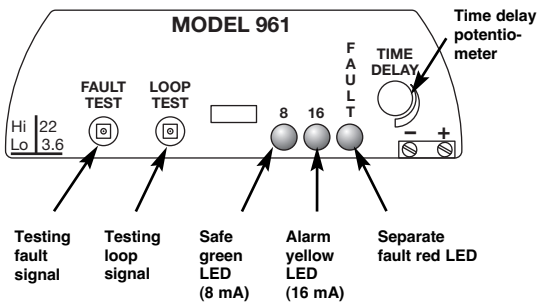

SET UP AND FUNCTIONS

Set up

High – Low Level Failsafe selection:^①

In «Hi» position, the current will shift to 12/16 mA (report alarm) when the transducer is **wet**.

In «Lo» position, the current will shift to 12/16 mA (report alarm) when the transducer is **dry**.

In both positions, the current will stay at 8 mA to report a safe condition.

Fault selection:





Select for which signal the unit should report a malfunction ≥ 22 mA or $\leq 3,6$ mA

Time delay setting:

Turning the potentiometer clockwise will increase the time delay from 0,5 s to 45 s. Time delay is typically used where turbulence, boiling or splashing can cause false level alarms.

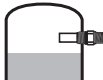





Indication

Echotel 961

Failsafe ^① mode	Level	Output signal	8 mA green LED	16 mA yellow LED	Fault red LED
«Hi» High Level Failsafe		8 mA (± 1 mA)	ON	OFF	OFF
		16 mA (± 1 mA)	OFF	ON	OFF
«Lo» Low Level Failsafe		8 mA (± 1 mA)	ON	OFF	OFF
		16 mA (± 1 mA)	OFF	ON	OFF

Fault LED is ON = Fault indication

Echotel 962

Failsafe mode	Level	Output signal	8 mA green LED	12 mA yellow LED	16 mA red LED
«Hi» High Level Failsafe		8 mA (± 1 mA)	ON	OFF	OFF
		12 mA (± 1 mA)	OFF	ON	OFF
		16 mA (± 1 mA)	OFF	OFF	ON
«Lo» Low Level Failsafe		8 mA (± 1 mA)	ON	OFF	OFF
		12 mA (± 1 mA)	OFF	ON	OFF
		16 mA (± 1 mA)	OFF	OFF	ON

All LED's OFF = Fault indication

^① Use the following settings to replace Echotel 915 series with the new Echotel 961 series:
 For High Level Failsafe, use «Lo» setting = low current draw (from 16 mA (safe) to 8 mA (alarm))
 For Low Level Failsafe, use «Hi» setting = high current draw (from 8 mA (safe) to 16 mA (alarm))

Manual Testing

Loop Test: (8 mA / 12mA / 16mA):

Pressing the “Loop Test” pushbutton, will manually test the loop and connected actuators/indicators. The loop test forces the output and corresponding LED’s to shift from 8 mA to 12 mA (only 962) to 16 mA back to 8 mA. The time delay setting is not active during testing.

Fault Test (3.6 mA /22 mA):

Pressing the “Fault Test” pushbutton for min 2 s, will manually test the fault output and connected actuators/indicators. The fault test simulates a circuit failure and forces the output to either ≤ 3.6 mA or ≥ 22 mA. The time delay setting is not active during testing.

Troubleshooting

Problem	Action/Indication	Solution
No loop signal	No LED’s are ON	Check wiring / input power Check for malfunction (962). See below
No change in output between wet gap / dry gap	Gap may be plugged by solids / dense foam	Clean the transducer
	Gap is out of reach of liquid	Check mounting section on page 2 and relocate the unit or check blocking valves.
Chattering output	Excessive aeration / Turbulence	Introduce a time delay
		Check input power
		Relocate the switch
Fault LED is ON (961) All LED’s OFF (962)	A system fault has been detected	Check input power
	Press «Loop Test» pushbutton to identify the problem:	
	* --- * : 1 flash (red LED)	Check wiring between transducer and electronics or replace transducer.
	** --- ** : 2 flashes (red LED)	Replace electronics
	*** --- *** : 3 flashes (red LED)	The unit senses excessive noise interference. Check shield connection or eliminate interference from a walkie-talkie, radio or other nearby source

REPLACEMENT PARTS

Replacing electronics/transducer

Echotel electronics can be removed in the field under process conditions. Follow below steps to exchange electronics/transducer:

Note: Adjust set up of the replacing electronics following the settings of the old electronics (see configuration section)

1. Disconnect power before removing the housing cover
2. Remove power/output wires (a)
3. (Skip step 3 if hygienic housing.) Click out the protection cap of the electronics (b)
4. Remove the 2 bracket screws and slide out electronics (c)
5. Remove the transducer wires (see Wiring section) (d)
6. Re-assemble following the same procedure in opposite way. Make sure that the tip on the bracket of the electronic block is seated properly in the corresponding recess in the housing base - (e)

Replacement parts

Partn°:

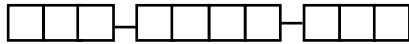

Digit in partn°:

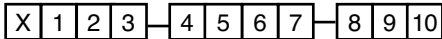

X = product with a specific customer requirement

Serial n°:



See nameplate, always provide complete partn° and serial n° when ordering spares.

No.	Description	Part Number	
1	Cast aluminium cover (digit 10 = 0 or 1) Blind With window	004-9192-004 036-4410-010	
	Cast stainless steel cover (digit 10 = 2 or 3) Blind	004-9192-023	
	Deep drawn stainless steel cover (digit 10 = 4 or 5) Blind	036-5702-003	
	With window	036-5702-002	
2	"O"-Ring digit 10 = 0, 1, 2 or 3 digit 10 = 4 or 5	012-2201-237 012-2201-155	
	3	Electronic module for industrial housing (digit 10 = 0, 1, 2 or 3) 961 - ATEX Exi/Exd 961 - Weatherproof 962	089-7259-005 089-7259-003 089-7258-003
Electronic module for hygienic housing (digit 10 = 4 or 5) 961 962		089-7256-003 089-7257-003	
4		Transducer	consult factory

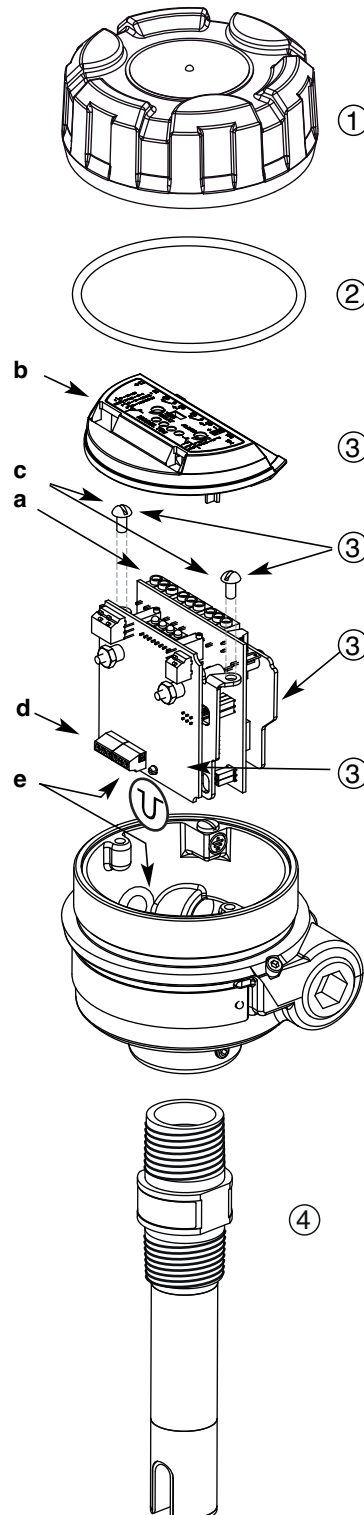

MODEL IDENTIFICATION

A complete measuring system consists of:

1. Echotel® electronics
2. Echotel® transducer

1. Code for Echotel® electronics

BASIC MODEL NUMBER

9 6 1	Echotel® 961 electronics for single setpoint 9M1 transducers
9 6 2	Echotel® 962 electronics for dual setpoint 9M2 transducers

INPUT POWER

5 0 A	24 V DC 2-wire loop powered electronics with current shift output
-------	---

ACCESSORIES

0	Blind housing cover
1	Housing cover with glass window (for aluminium housings only)

MOUNTING

0	Integral mount electronics
---	----------------------------

APPROVALS

A	ATEX II 1 G EEx ia IIC T5, intrinsically safe	- except deep drawn SST housing
C	ATEX II 1/2 G EEx d IIC T6, flameproof enclosure	- except deep drawn SST housing
1	Weatherproof	- except deep drawn SST housing
7	Weatherproof	- deep drawn SST housing

HOUSING / CABLE ENTRY

1	Cast aluminium housing with M20 x 1,5 cable entry (2 entries – one plugged)
0	Cast aluminium housing with 3/4" NPT cable entry (2 entries – one plugged)
3	Cast stainless steel with M20 x 1,5 cable entry (2 entries – one plugged)
2	Cast stainless steel with 3/4" NPT cable entry (2 entries – one plugged)
5	Deep drawn 304 stainless steel with M20 x 1,5 cable entry (2 entries – one plugged)
4	Deep drawn 304 stainless steel with 1/2"NPT cable entry (2 entries – one plugged)

9	6	X	5	0	A	0		
---	---	---	---	---	---	---	--	--

complete code for Echotel® electronics

→ X = product with a specific customer requirement

MODEL IDENTIFICATION

2. Code for Echotel® transducer

BASIC MODEL NUMBER

9 M 1	Echotel® 961 transducer with single setpoint
9 M 2	Echotel® 962 transducer with dual setpoints

TRANSDUCER MATERIALS (use only metal transducers for hazardous area)

A	316/316L (1.4401/1.4404) stainless steel
B	Hastelloy® C (2.4819) – only available with 9M1
C	Monel® (2.4360) – only available with 9M1
P	CPVC
R	Kynar® (PVDF) – only available with 9M1
S	316/316L (1.4401/1.4404) stainless steel with 0,5 µm Ra (20 Ra) surface finish

PROCESS CONNECTION

Threaded (plastic transducers are only available with 3/4" NPT connection)

1 1	3/4" NPT
2 1	1" NPT
2 2	1" BSP (G 1")

ANSI Flanges for metal transducers

2 3	1"	150 lbs	ANSI RF
2 4	1"	300 lbs	ANSI RF
2 5	1"	600 lbs	ANSI RF
3 3	1 1/2"	150 lbs	ANSI RF
3 4	1 1/2"	300 lbs	ANSI RF
3 5	1 1/2"	600 lbs	ANSI RF
4 3	2"	150 lbs	ANSI RF
4 4	2"	300 lbs	ANSI RF
4 5	2"	600 lbs	ANSI RF

EN (DIN) Flanges for metal transducers

B B	DN 25	PN 16/25/40	EN 1092-1 Type A
B C	DN 25	PN 63/100	EN 1092-1 Type B2
C B	DN 40	PN 16/25/40	EN 1092-1 Type A
C C	DN 40	PN 63/100	EN 1092-1 Type B2
D A	DN 50	PN 16	EN 1092-1 Type A
D B	DN 50	PN 25/40	EN 1092-1 Type A
D D	DN 50	PN 63	EN 1092-1 Type B2
D E	DN 50	PN 100	EN 1092-1 Type B2

ANSI Flanges for plastic transducers^①

2 3	1"	150 lbs	ANSI RF ^②
3 3	1 1/2"	150 lbs	ANSI RF ^②
4 3	2"	150 lbs	ANSI RF ^②

EN (DIN) Flanges for plastic transducers^①

B A	DN 25	PN 16	EN 1092-1 Type A
C A	DN 40	PN 16	EN 1092-1 Type A
D A	DN 50	PN 16	EN 1092-1 Type A

- ① CPVC flanges for CPVC transducers, Kynar® clad SST flanges for Kynar® transducers
 ② FF (flat face) flanges for CPVC transducers

Hygienic

3 T	1" - 1 1/2" Tri-clamp®
4 T	2" Tri-clamp®
V V	DN 65 Varivent®

B S	DN 25	DIN 11851
C S	DN 40	DIN 11851
D S	DN 50	DIN 11851

SENSOR TYPE

A	Standard sensor: min -40 °C / max +165 °C (-40 °F / +325 °F)
C	Low temperature sensor: min -80 °C / max +120 °C (-110 °F / +250 °F) – only available with 9M1-A

ACTUATION LENGTH – specify per cm (0.39") increment
 Total insertion length = actuation length + 6 mm (0.25")

9M1 transducers

0 0 3	Minimum 3 cm (1.2") – for metal transducers with NPT connections only
0 0 5	Minimum 5 cm (2") – for all other connections
3 3 0	Maximum 330 cm (130")

9M2 transducers "A" length

specify "B" length separately (min 8 cm and max 318 cm between "A" and "B")

0 1 3	Minimum 13 cm (5.1") – for metal transducers with NPT connections only
0 1 5	Minimum 15 cm (5.9") – for all other connections
3 3 0	Maximum 330 cm (130")

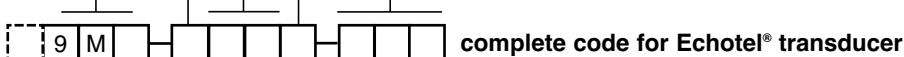

→ X = product with a specific customer requirement

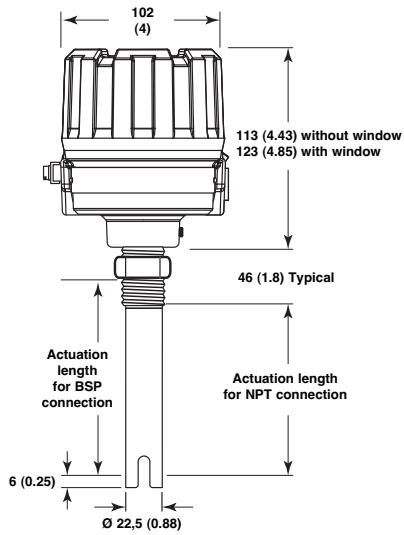

961 - Threaded connection

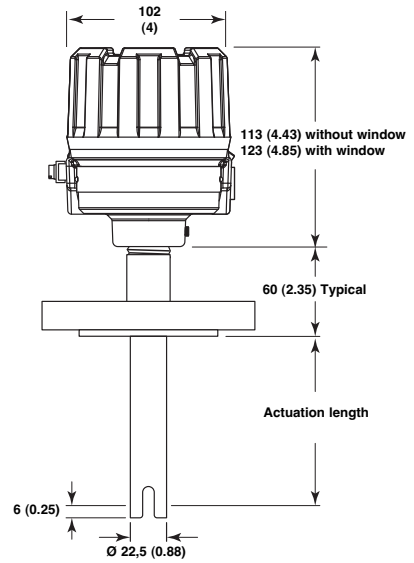

961 - Flanged connection

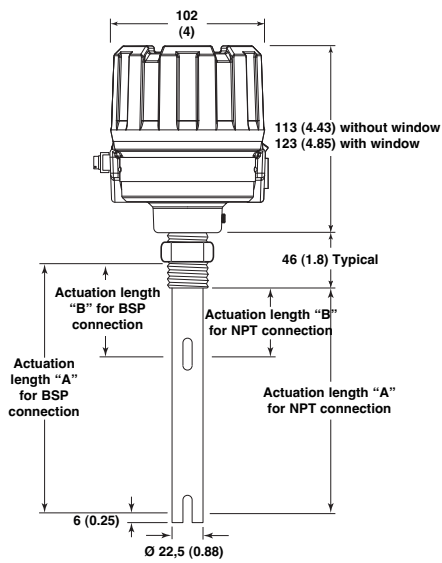

962 - Threaded connection

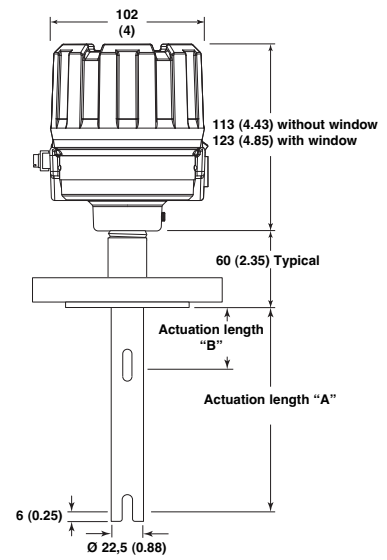

962 - Flanged connection

DIMENSIONS IN mm (inches)

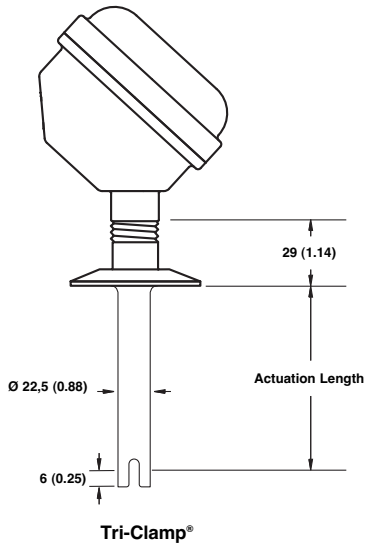
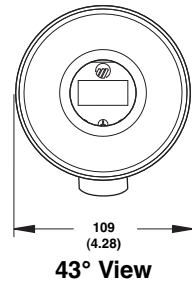
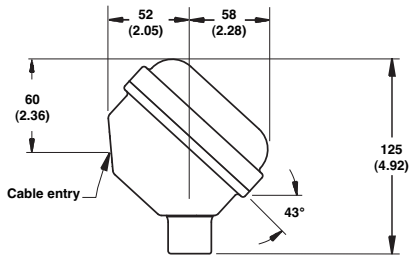

Tri-Clamp®

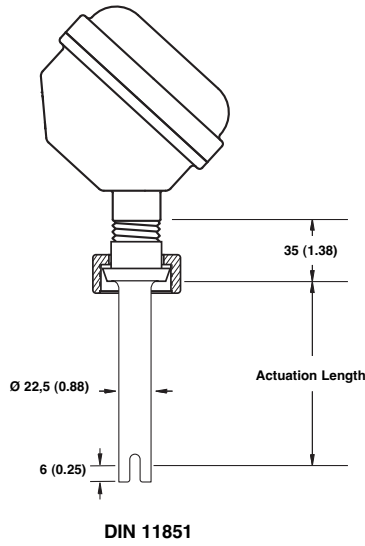

DIN 11851

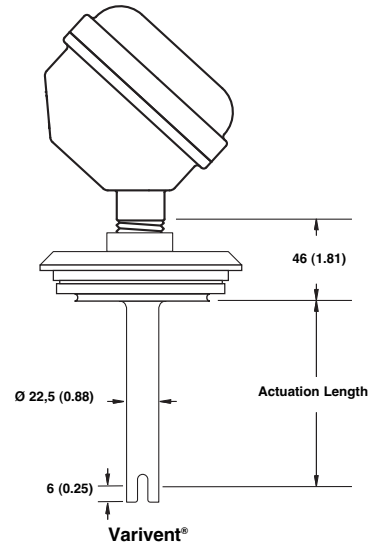

Varivent®

PRESSURE / TEMPERATURE RATINGS

Kynar® Transducer Ratings

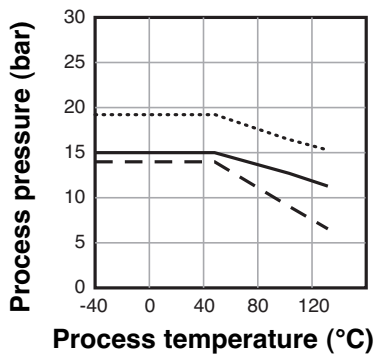

CPVC Transducer Ratings

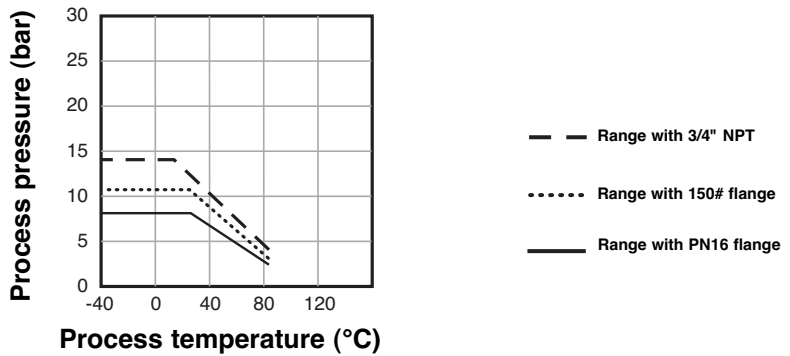

Metal Transducer Ratings

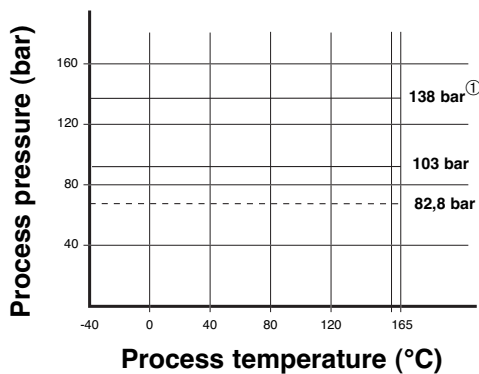

- 316/316L (1.4401/1.4404) ②
- Hastelloy® C (2.4819)
- - - Monel® (2.4360)

① Only applicable to NPT-connections with actuation length = 3 cm and BSP/ANSI/EN (DIN)-connections with actuation length = 5 cm
 ② For low temperature sensor: from -80 °C up to +120 °C

SPECIFICATIONS

Electronics specifications

Description		Specification
Input Voltage		2 wire loop powered, 11 - 35 V DC
Power Consumption		< 1 Watt
Output		961 : 8 mA (safe), 16 mA (alarm) ± 1 mA 962 : 8 mA (safe), 12 mA (lower gap alarm), 16 mA (upper gap alarm) ± 1 mA 961/962 : ≤ 3,6 or ≥ 22 mA error signal
Time delay		0,5 to 45 s adjustable (in addition to transducer response time)
Indication		LED's for process alarm status, malfunction (error of transducer, electronics or electrical noise interference)
Selftest	Automatic	Continuously verifies electronics, transducer and noise interference
	Manual	Via pushbutton for checking alarm output(s) and error output/function.
Housing material		IP66, cast aluminium, cast stainless steel or deep drawn 304 stainless steel (IP 67)
Approvals ^①		ATEX II 1 G EEx ia IIC T5, intrinsically safe (units with metal transducers) ATEX II 1/2 G EEx d IIC T6, flameproof enclosure (units with metal transducers) Overfill prevention TÜV - WHG § 19 / VLAREM II 5.17.7 Other approvals are available, consult factory for more details
SIL (Safety Integrity Level)		Functional safety to SIL 2 in accordance to IEC 61508 – SFF > 90 % Full FMEDA report and declaration sheets available at request
Electrical data		U _i = 28,4 V, I _i = 94 mA, P _i = 0,67 W
Equivalent data		C _i = 10,4 nF (961) / C _i = 60 nF (962), L _i = 400 μH
Shock/Vibration		ANSI/ISA-S71.03 Class SA1 (shock), ANSI/ISA-S71.03 Class VC2 (vibration)
Net weight		Aluminium / Deep drawn 304 SST: 1 kg (2.2 lbs) – electronics only Cast SST: 2,5 kg (5.5 lbs) – electronics only

^① Only available with cast aluminium or cast stainless steel housings

Performance

Description	Specification
Response time	0,5 s typical
Repeatability	± 2 mm (0.078")
Ambient Temperature	-40 °C to +70 °C (-40 °F to +160 °F)
Humidity	0-99 %, non-condensing
Electromagnetic Compatibility	Meets CE requirements (EN 61326: 1997 + A1 + A2) and NAMUR NE 21

Transducer specifications

Description	Plastic transducers	Metal transducers
Material	CPVC Kynar® (PVDF)	316/316L SST (1.4401/1.4404) Hastelloy® C (2.4819) Monel® (2.4360)
Mounting	Threaded (NPT/BSP) – Flanged (ANSI - EN (DIN)) – Hygienic	
Actuation length	From 5 cm up to 330 cm (2" up to 130")	From 3 cm up to 330 cm (1.2" up to 130")
Process temp. (consult temp/press. graphs)	-40 °C to +120 °C (-40 °F to +250 °F) – PVDF -40 °C to +80 °C (-40 °F to +180 °F) – CPVC	-40 °C to +165 °C (-40 °F to +325 °F) – standard -80 °C to +120 °C (-110 °F to +220 °F) – low temperature version in 316/316L SST
Max pressure (consult temp/press. graphs)	13,8 bar @ +40 °C (200 psi @ +100 °F) for NPT threaded units	82,8 bar (1200 psi) for Monel transducers Consult temp/press. graphs for other materials
	Flanged models are downrated to the design pressure of the selected flange	
Max viscosity	10.000 cP	

IMPORTANT

SERVICE POLICY

Owners of Magnetrol products may request the return of a control; or, any part of a control for complete rebuilding or replacement. They will be rebuilt or replaced promptly. Magnetrol International will repair or replace the control, at no cost to the purchaser, (or owner) **other than transportation cost** if:

- a. Returned within the warranty period; and,
- b. The factory inspection finds the cause of the malfunction to be defective material or workmanship.

If the trouble is the result of conditions beyond our control; or, is **NOT** covered by the warranty, there will be charges for labour and the parts required to rebuild or replace the equipment.

In some cases, it may be expedient to ship replacement parts; or, in extreme cases a complete new control, to replace the original equipment before it is returned. If this is desired, notify the factory of both the model and serial numbers of the control to be replaced. In such cases, credit for the materials returned, will be determined on the basis of the applicability of our warranty.

No claims for misapplication, labour, direct or consequential damage will be allowed.

RETURNED MATERIAL PROCEDURE

So that we may efficiently process any materials that are returned, it is essential that a "Return Material Authorisation" (RMA) form will be obtained from the factory. It is mandatory that this form will be attached to each material returned. This form is available through Magnetrol's local representative or by contacting the factory. Please supply the following information:

1. Purchaser Name
2. Description of Material
3. Serial Number and Ref Number
4. Desired Action
5. Reason for Return
6. Process details

Any unit that was used in a process must be properly cleaned in accordance with the proper health and safety standards applicable by the owner, before it is returned to the factory.

A material Safety Data Sheet (MSDS) must be attached at the outside of the transport crate or box.

All shipments returned to the factory must be by prepaid transportation. Magnetrol **will not accept** collect shipments.

All replacements will be shipped Ex Works.

UNDER RESERVE OF MODIFICATIONS

BULLETIN N°: BE 51-646.5
EFFECTIVE: MAY 2010
SUPERSEDES: April 2008



www.magnetrol.com

BENELUX FRANCE	Heikensstraat 6, 9240 Zele, België -Belgique Tel. +32 (0)52.45.11.11 • Fax. +32 (0)52.45.09.93 • E-Mail: info@magnetrol.be
DEUTSCHLAND	Alte Ziegelei 2-4, D-51491 Overath Tel. +49 (0)2204 / 9536-0 • Fax. +49 (0)2204 / 9536-53 • E-Mail: vertrieb@magnetrol.de
INDIA	C-20 Community Centre, Janakpuri, New Delhi - 110 0058 Tel. +91 (11) 41661840 • Fax +91 (11) 41661843 • E-Mail: info@magnetrolindia.com
ITALIA	Via Arese 12, I-20159 Milano Tel. +39 02 607.22.98 (R.A.) • Fax. +39 02 668.66.52 • E-Mail: mit.gen@magnetrol.it
U.A.E.	DAFZA Office 5EA 722 • PO Box 293671 • Dubai Tel. +971-4-6091735 • Fax +971-4-6091736 • E-Mail: info@magnetrol.ae
UNITED KINGDOM	Unit 1 Regent Business Centre, Jubilee Road Burgess Hill West Sussex RH 15 9TL Tel. +44 (0)1444 871313 • Fax +44 (0)1444 871317 • E-Mail: sales@magnetrol.co.uk