

# ECLIPSE™

Model 705 with  
Foundation Fieldbus Digital Output  
705 software 1.0

Foundation Fieldbus Operating Manual

*Guided Wave Radar  
Level Transmitter*

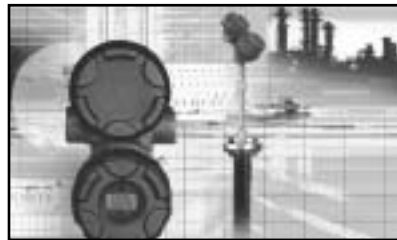

---

## Read this Manual Before Installing

This manual provides information on the Eclipse Model 705 transmitter with Foundation Fieldbus Output. It is important that all instructions are read carefully.

### Safety Messages

The Eclipse system is designed for use in Category II, Pollution Degree 2 installations. Follow all standard industry procedures for servicing electrical and computer equipment when working with or around high voltage. Always shut off the power supply before touching any components. Although high voltage is not present in this system, it may be present in other systems.

Electrical components are sensitive to electrostatic discharge. To prevent equipment damage, observe safety procedures when working with electrostatic sensitive components.

This device complies with Part 15 of the FCC rules. Operation is subject to the following two conditions: (1) This device may not cause harmful interference, and (2) This device must accept any interference received, including interference that may cause undesired operation.

**WARNING!** Explosion hazard. Do not connect or disconnect designs rated Explosion proof or Non-incendive unless power has been switched off and/or the area is known to be non-hazardous

### Low Voltage Directive

For use in Installations Category II, Pollution Degree 2. If equipment is used in a manner not specified by the manufacturer, protection provided by equipment may be impaired.

### Notice of Copyright and Limitations

Copyright © 2005 Magnetrol International  
All rights reserved

Magnetrol reserves the right to make changes to the product described in this manual at any time without notice. Magnetrol makes no warranty with respect to the accuracy of the information in this manual.

## Warranty

All Magnetrol/STI electronic level and flow controls are warranted free of defects in materials or workmanship for one full year from the date of original factory shipment. If returned within the warranty period; and, upon factory inspection of the control, the cause of the claim is determined to be covered under the warranty; then, Magnetrol/STI will repair or replace the control at no cost to the purchaser (or owner) other than transportation.

Magnetrol/STI shall not be liable for misapplication, labor claims, direct or consequential damage or expense arising from the installation or use of equipment. There are no other warranties expressed or implied, except special written warranties covering some Magnetrol/STI products.

### Quality assurance

The quality assurance system in place at Magnetrol/STI guarantees the highest level of quality throughout the company. Magnetrol is committed to providing full customer satisfaction both in quality products and quality service.

Magnetrol's quality assurance system is registered to ISO 9001 affirming its commitment to known international quality standards providing the strongest assurance of product/service quality available.



# Foundation Fieldbus – Eclipse Guided Wave Radar Transmitter

## Table of Contents

<b>1.0 Fieldbus Overview</b>		
1.1 Description	1	
1.2 Benefits	2	
1.3 Device Configuration	2	
1.4 Intrinsic Safety	3	
1.5 Link Active Scheduler (LAS)	3	
<b>2.0 Function Blocks</b>		
2.1 Overview	4	
2.1.1 Resetting the Model 705 Function Blocks	4	
2.1.2 Universal Fieldbus Block Parameters	5	
2.2 Resource Block	6	
2.3 GWR Transducer Block	8	
2.3.1 GWR Transducer Block Parameters	9	
2.3.1.1 Transducer Block Priority	11	
2.3.2 Password Parameters	12	
2.3.2.1 Procedure for Changing User Password	13	
2.3.2.2 Displaying the User Password	13	
2.3.2.3 Password Operations	14	
2.3.3 Primary Value (PV) Parameters	14	
2.3.4 Configuration Parameters	15	
2.3.5 Calibration Parameters	16	
2.3.5.1 GWR Transducer Field User Calibration	17	
2.3.6 Factory Parameters	19	
2.3.7 Miscellaneous Sensor Parameters	20	
2.3.8 Discrete Switch Parameters	20	
2.3.9 Firmware Version	21	
2.4 Analog Input Block	22	
2.5 Digital Input Block	23	
2.6 PID Block	25	
<b>3.0 Configuring the Level Transmitter</b>	<b>26</b>	
<b>4.0 Diagnostic Parameters</b>	<b>27</b>	
4.1 Simulation Feature	29	
<b>5.0 Documentation</b>	<b>29</b>	
5.1 Data Sheet for Individual Instrument	30	
5.2 Data sheet for Multiple Devices	31	
<b>6.0 Reference Information</b>	<b>32</b>	
6.1 Troubleshooting	32	
6.1.1 Troubleshooting System Problems	32	
6.1.2 Error Messages	33	
6.1.3 Troubleshooting Guide	34	
6.1.3.1 FF Segment Checklist	34	
6.2 Agency Approvals	35	
6.2.1 Agency Specifications – Intrinsically Safe Installation	36	
6.2.2 Agency Specifications – Explosion Proof Installation	36	
6.2.3 Agency Specifications – Foundation Fieldbus System	37	
6.3 Specifications	38	
6.3.1 Functional	38	
6.3.2 Performance	39	
6.4 Model Numbers	40	
6.4.1 Transmitter	40	
6.4.2 Probe	41	
6.5 References	43	
<b>Configuration Data Sheet</b>	<b>44</b>	

## 1.0 Fieldbus Overview

### 1.1 Description

Foundation Fieldbus is a digital communications system that serially interconnects devices in the field. A Fieldbus system is similar to a Distributed Control System (DCS) with two exceptions:

- Although a Fieldbus system can use the same physical wiring as an existing 4–20 mA device, Fieldbus devices are not connected point to point, but rather are multidropped and wired in parallel on a single pair of wires (referred to as a segment).
- Fieldbus is a system that allows the user to distribute control across a network. Fieldbus devices are smart and actually maintain control over the system.

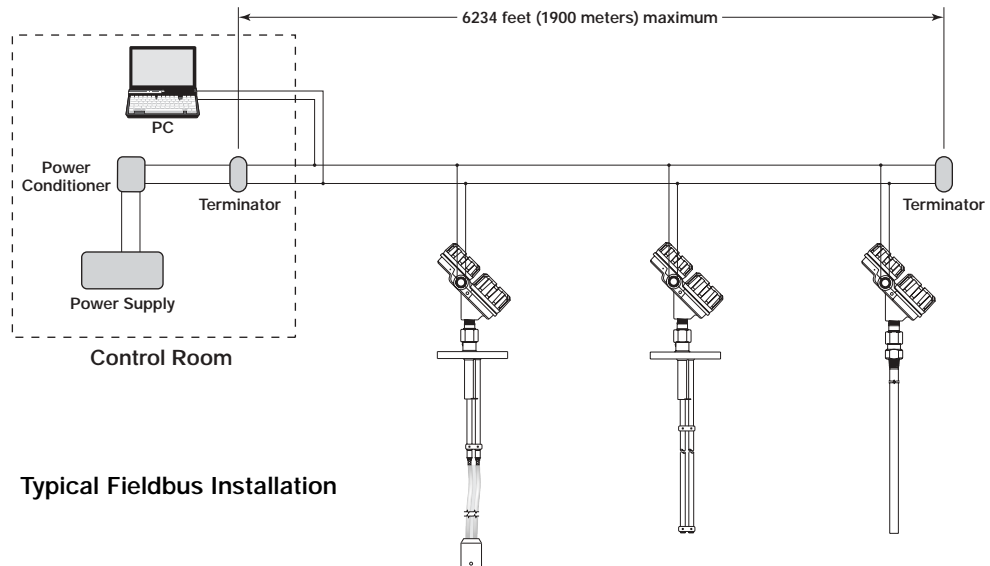

Typical Fieldbus Installation

Unlike 4–20 mA analog installations in which the two wires carry a single variable (the varying 4–20 mA current), a digital communications scheme such as Fieldbus considers the two wires as a network. The network can carry many process variables as well as other information. The Eclipse Model 705FF transmitter is a Foundation Fieldbus registered device that communicates with the H1 Foundation Fieldbus protocol operating at 31.25 kbits/sec. The H1 physical layer is an approved IEC 61158 standard.

An IEC61158 shielded twisted pair wire segment can be as long as 6234 feet (1900 meters) without a repeater. Up to 4 repeaters per segment can be used to extend the distance. The maximum number of devices allowed on a Fieldbus segment is 32 although this depends on the current draw of the devices on any given segment.

---

Details regarding cable specifications, grounding, termination, and other network information can be found in IEC 61158 or the wiring installation application guide AG-140 at [www.fieldbus.org](http://www.fieldbus.org).

## 1.2 Benefits

The benefits of Fieldbus can be found throughout all phases of an installation:

1. **Design/Installation:** Connecting multiple devices to a single pair of wires means less wire and fewer I/O equipment. Initial Engineering costs are also reduced because the Fieldbus Foundation requires interoperability, defined as “the ability to operate multiple devices in the same system, regardless of manufacturer, without a loss of functionality.” All Foundation Fieldbus devices must be tested for interoperability by the Fieldbus Foundation. Magnetrol Model 705FF device registration information can be found at [www.fieldbus.org](http://www.fieldbus.org).
2. **Operation:** With control now taking place within the devices in the field, better loop performance and control are the result. A Fieldbus system allows for multiple variables to be brought back from each device to the control room for additional trending and reporting.
3. **Maintenance:** The self-diagnostics residing in the smart field devices minimizes the need to send maintenance personnel to the field.

## 1.3 Device Configuration

### Device Descriptions

The function of a Fieldbus device is determined by the arrangement of a system of blocks defined by the Fieldbus Foundation. The types of blocks used in a typical User Application are described as follows:

**Resource Block** describes the characteristics of the Fieldbus device such as the device name, manufacturer, and serial number.

**Function Blocks** are built into the Fieldbus devices as needed to provide the desired control system behavior. The input and output parameters of function blocks can be linked over the Fieldbus. There can be numerous function blocks in a single User Application.

**Transducer Blocks** contain information such as calibration date and sensor type. They are used to connect the sensor to the input function blocks.

---

An important requirement of Fieldbus devices is the interoperability concept mentioned above. Device Description (DD) technology is used to achieve this interoperability. The DD provides extended descriptions for each object and provides pertinent information needed by the host system.

DDs are similar to the drivers that your personal computer (PC) uses to operate peripheral devices connected to it. Any Fieldbus host system can operate with a device if it has the proper DD and Common File Format (CFF) for that device.

The most recent DD and CFF files can be found on Magnetrol's web site at [magnetrol.com](http://magnetrol.com) and on the Foundation Fieldbus web site at [fieldbus.org](http://fieldbus.org).

#### 1.4 Intrinsic Safety

The H1 physical layer supports Intrinsic Safety (IS) applications with bus-powered devices. To accomplish this, an IS barrier or galvanic isolator is placed between the power supply in the safe area and the device in the hazardous area.

H1 also supports the Fieldbus Intrinsically Safe Concept (FISCO) model which allows more field devices in a network. The FISCO model considers the capacitance and inductance of the wiring to be distributed along its entire length. Therefore, the stored energy during a fault will be less and more devices are permitted on a pair of wires. Instead of the conservative entity model, which only allows about 90 mA of current, the FISCO model allows a maximum of 110 mA for Class II C installations and 240 mA for Class II B installations.

FISCO certifying agencies have limited the maximum segment length to 1000 meters because the FISCO model does not rely on standardized ignition curves.

The Eclipse Model 705 is available with entity IS, FISCO IS, FNICO non-incendive, or explosion proof approvals.

#### 1.5 Link Active Scheduler (LAS)

The Eclipse Model 705 with Foundation Fieldbus contains a Link Active Scheduler (LAS). The LAS controls all communication on a Foundation Fieldbus segment. It maintains the "Live List" of all devices on a segment, coordinates both the cyclic and acyclic timing and, at any given time, controls which device publishes data via Compel data (CD) and Pass Token (PT).

The primary LAS is usually maintained in the host system, but in the event of a failure, all associated control can be transferred to a backup LAS in a field device such as the Eclipse Model 705.

---

## 2.0 Function Blocks

### 2.1 Overview

The Eclipse Model 705 Guided Wave Radar Level Transmitter operates on the principle of Time Domain Reflectometry (TDR). Refer to Bulletins 57-101 and 57-600 for more information on the Eclipse family of products.

The Eclipse Model 705FF is an advanced Guided Wave Radar (GWR) level transmitter with five Foundation Fieldbus Function Blocks. The idea of Function Blocks, which a user can customize for a particular application, is a key concept of Fieldbus topology. Function Blocks consist of an algorithm, inputs and outputs, and a user-defined name.

NOTE: The RESOURCE block, the TRANSDUCER block, one AI block, one PID block, and two DI blocks are instantiated at the factory before the transmitter is shipped. All other function blocks must be instantiated by the customer to be available for operation.

Instantiation is the process of creating a software object and initializing its associated fields including all of the variables of the entire object.

The TRANSDUCER output is available to the network through the ANALOG or DISCRETE INPUT block.

- The ANALOG INPUT block (AI) takes the TRANSDUCER level value and makes it available as an analog value to other function blocks. The AI block has scaling conversion, filtering, and alarm functions.
- The DISCRETE INPUT blocks (DI) take one of the two TRANSDUCER digital output values and make it available as a logical value to other function blocks. The DI block has optional inversion, filtering, and alarm functions.

The PID CONTROL block (PID) is a universal control system component. The PID block has control point setting, filtering, alarm function, feed forward and tracking algorithms. The PID input can be from any scaled function block on the network.

#### 2.1.1 Resetting the Model 705 Function Blocks

The Model 705 is configured at the factory with the Resource Block, the GWR Transducer Block, one AI block, one PID block and two DI blocks instantiated. The number and type of instantiated block is adjustable in the field. Selecting the DEFAULT option from the Resource block RESET parameter will return the Model 705 to the factory configuration. Use the configuration tool Upload command to attach the Model 705 instantiated block to the device,

---

then after exporting the device tags, use the configuration tool Download command to load the new strategy with the factory configuration instantiated.

### 2.1.2 Universal Fieldbus Block Parameters

The following are general descriptions of the parameters common to all blocks. Additional information for a given parameter is described later in that specific block section.

**ST\_REV (static data revision):** a read only parameter that gives the revision level of the static data associated with the block. This parameter will be incremented each time a static parameter attribute value is written—whether it is changed or not. It is a vehicle for tracking changes in static parameter attributes.

**TAG\_DESC (tag descriptor):** a user assigned parameter that describes the intended application of any given block.

**STRATEGY:** a user assigned parameter that identifies groupings of blocks associated with a given network connection or control scheme.

**ALERT\_KEY:** a user assigned parameter which may be used in sorting alarms or events generated by a block.

**MODE\_BLK:** a structured parameter composed of the actual mode, the target mode, the permitted mode, and the normal mode of operation of a block.

- The actual mode is set by the block during its execution to reflect the mode used during execution.
- The target mode may be set and monitored through the mode parameter.
- The permitted modes are listed for each block.
- The normal mode is the desired operating mode of the block. The block must be in an automatic mode for normal operation. The MODE parameter must be O/S (out of service) to change configuration and calibration parameters in that function block. When in O/S, the normal algorithm is no longer executed and any outstanding alarms are cleared.

NOTE: All blocks must be in an operating mode for the device to operate. This requires the Resource Block in "AUTO" and the Transducer Block in "AUTO" before the Function Blocks can be placed in other than O/S (out of service).

**BLK\_ERR (block error):** a parameter that reflects the error status of hardware or software components associated with, and directly affecting, the correct operation of a block.

---

## 2.2 Resource Block

The RESOURCE block contains data specific to the Model 705 hardware along with some information about the firmware.

NOTE: The Resource Block has no control function and must be instantiated for all configurations.

**MODE\_BLK:** Must be in AUTO in order for the remaining blocks in the transmitter to operate.

NOTE: O/S mode stops all function block execution in the transmitter.

**RS\_STATE (Resource State):** identifies the state of the RESOURCE block state machine. Under normal operating conditions, it should be “On-Line.”

**TEST\_RW (Test Read/Write):** a parameter only used during conformance testing by the Fieldbus Foundation.

**DD\_RESOURCE:** a string identifying the tag of the resource that contains the Device Description for this device.

**MANUFAC\_ID:** contains Magnetrol International's Foundation Fieldbus manufacturer's ID number, which is 0x000156.

**DEV\_TYPE:** the model number of the Eclipse Model 705 transmitter (0x0705). It is used by interface devices to locate the Device Descriptor (DD) file for this product.

**DEV\_REV:** contains the firmware revision of the Eclipse Model 705 transmitter. It is used by interface devices to correctly select the associated DD.

**DD\_REV:** contains the revision of the DD associated with the version of firmware in the Eclipse Model 705 transmitter. It is used by interface devices to correctly select the associated DD.

**GRANT\_DENY:** not used

**HARD\_TYPES:** indicates the types of hardware available as channel numbers. This parameter is blank in the Eclipse Model 705.

**RESTART:** Default and Processor selections are available. Default will reset the Model 705 to the block configuration instantiated at the factory. Refer to “Resetting the Model 705 Function Blocks” in Section 2.1.1.

**FEATURES:** a list of the features available in the transmitter. The Model 705 features include Reports, Faultstate, and Software Write Locking.

**FEATURES\_SEL:** allows the user to turn Features on or off.

---

**CYCLE\_TYPE:** identifies the block execution methods that are available.

**CYCLE\_SEL:** allows the user to select the block execution method.

**MIN\_CYCLE\_T:** the time duration of the shortest cycle interval. It puts a lower limit on the scheduling of the resource.

**MEMORY\_SIZE:** the available configuration memory. It is highly recommended that this parameter be checked before attempting a download.

**NV\_CYCLE\_T:** the minimum time interval between copies of non-volatile (NV) parameters to NV memory. NV memory is only updated if there has been a significant change in the dynamic value and the last value saved will be available for the restart procedure. A value of "0" means it will never be automatically copied. Entries made by human interface devices to NV parameters are copied to non-volatile memory at the time of entry.

NOTE: After completing a large copy, allow several minutes before removing power from the Eclipse Model 705 transmitter to ensure that all data has been saved.

**FREE\_SPACE:** shows the amount of available memory for further configuration. The value is zero percent in a pre-configured device.

**FREE\_TIME:** the amount of the block processing time that is free to process additional blocks.

**SHED\_RCAS:** the time duration at which to give up computer writes to function block RCas locations. Shed from RCas will never happen when SHED\_RCAS = 0.

**SHED\_ROUT:** the time duration at which to give up computer writes to function block ROut locations. Shed from ROut will never happen when SHED\_ROUT = 0.

**FAULT\_STATE, SET\_FSTATE, CLR\_FSTATE:** these only apply to output function blocks. (The Model 705 has no output function blocks).

**MAX\_NOTIFY:** the maximum number of alert reports that the transmitter can send without getting a confirmation. The user can set the number low, to control alert flooding, by adjusting the LIM\_NOTIFY parameter value.

**LIM\_NOTIFY:** the maximum numbers of unconfirmed alert notify messages allowed. No alerts are reported if set to zero.

**CONFIRM\_TIME:** the time that the transmitter will wait for confirmation of receipt of a report before trying again. Retry will not occur if CONFIRM\_TIME = 0.

---

**WRITE\_LOCK:** will prevent any external change to the static or non-volatile data base in the Function Block Application of the transmitter. Block connections and calculation results will proceed normally, but the configuration will be locked.

**UPDATE\_EVT (Update Event):** is an alert generated by a write to the static data in the block.

**BLOCK\_ALM (Block Alarm):** is used for all configuration, hardware, connection, or system problems in the block. The cause of any specific alert is entered in the subcode field. The first alert to become active will set the Active status in the Status attribute. As soon as the Unreported status is cleared by the alert reporting task, another block alert may be reported without clearing the Active status, if the subcode has changed.

**ALARM\_SUM (Alarm Summary):** contains the current alert status, the unacknowledged states, the unreported states, and the disabled states of the alarms associated with the block.

**ACK\_OPTION (Acknowledge Option):** selects whether alarms associated with the block will be automatically acknowledged.

**WRITE\_PRI (Write Priority):** the priority of the alarm generated by clearing the write lock.

**WRITE\_ALM (Write Alarm):** the alert generated if the write lock parameter is cleared.

**ITK\_VER (ITK Version):** contains the version of the Interoperability Test Kit (ITK) used by the Fieldbus Foundation during their interoperability testing.

## 2.3 GWR Transducer Block

The GWR TRANSDUCER block is a custom function block of 55 parameters that supports the Eclipse Model 705FF level transmitter. It contains the GWR probe configuration, diagnostics, and calibration data and outputs level with status information.

The TRANSDUCER block parameters are grouped in a useful configuration. There are 23 read-only parameters and 32 read-write parameters within the TRANSDUCER block. The read-only parameters report the block status and operation modes. The read-write parameters affect the function block basic operation, level transmitter operation, calibration, and the Analog/Digital operation.

NOTE: The TRANSDUCER block must be instantiated for all configurations.

---

### 2.3.1 GWR Transducer Block Parameters

The first six parameters in the GWR TRANSDUCER block are the universal parameters discussed in section 2.1.1. The universal parameters are followed by these additional required parameters:

**UPDATE\_EVT (Update Event):** an alert generated by a write to the static data in the TRANSDUCER block.

**BLOCK\_ALM (Block Alarm):** used for all configuration, hardware, connection failure, or system problems in the block. The cause of the alert is entered in the subcode field. The first alert to become active will set the Active status in the Status attribute. As soon as the Unreported status is cleared by the alert reporting task, another block alert may be reported without clearing the Active status, if the subcode has changed.

**TRANSDUCER\_DIRECTORY:** typically an array containing the number of transducers and the starting index information for each of them. The Eclipse Model 705 has just one transducer so the array collapses to a single parameter of value 0.

**TRANSDUCER\_TYPE:** has value “705” which represents a calibrated Guided Wave Radar Level transmitter.

**XD\_ERROR (Transducer Error):** displays errors present in the TRANSDUCER block. If no errors exist, then it has a value of 0 which means “none.” Refer to Table 2.3.1.1 on page 11.

**COLLECTION\_DIRECTORY:** typically an array of values. The first value is the number of data collections, followed by the indices of each of the collections. Since there is only one collection for the Eclipse Model 705, the array reduces to a single element with a value of 0.

**DEVICE\_STATUS:** displays the status of the device. If more than one message exists, then the messages are displayed in priority order. The messages and their definitions are listed below from lowest to highest priority. Refer to Table 2.3.1.1 on page 11.

- **OK:** Reflects that the device is functioning properly.
- **OK?:** The transmitter is seeing an indication that the measurement may be deviating from the normal functioning state. However, it does not have enough information to definitively change to one of the other status conditions.
- **USER MODE:** The user password is enabled and user parameters can be modified via the local display on the transmitter. This is the default state of operation on the Fieldbus network.
- **DRY PROBE:** There is no process material on the probe.

- 
- **POSSIBLY FLOODED PROBE:** Indicates that a sequence of events has occurred in the process indicating that the process material is above the highest measurable point on the probe.
  - **INITIALIZING:** A temporary message indicating that the microprocessor is going through its initialization process.
  - **NEEDS CALIBRATION:** The device had been in the PARAMETERS DEFAULTED condition (explained below) and the transmitter has set all static parameters to their default values. The NEEDS CALIBRATION condition occurs when entering one or more configuration parameters to reconfigure the device and not re-entering the calibration parameters after the device has been in the PARAMETERS DEFAULTED condition. Since the default calibration for the Model 705 transmitter is FACTORY, the device will continue to operate in this state.

NOTE: If the user had previously performed a field calibration, that data has been lost. If you do not want to use the factory calibration, you must repeat a field calibration, which is explained in Section 2.3.5.

- **PARAMETERS INCORRECT:** The Eclipse Model 705 transmitter is detecting an end of probe signal that conflicts with the entered value of PROBE\_LENGTH.
- **NO LEVEL SIGNAL:** The Eclipse Model 705 does not detect a level signal or an end of probe signal.
- **NO FIDUCIAL SIGNAL:** The Eclipse Model 705 does not see the required fiducial (reference) signal at the top of the probe.
- **PARAMETERS DEFAULTED:** The Eclipse Model 705 has encountered an error reading non-volatile memory and has reverted all of the static parameters to their default values.
- **FACTORY MODE:** The factory password has been entered and is active.

The following Table 2.3.1.1 shows the relationship between BLOCK\_ERR, XD\_ERROR, PV quality and quality sub-status, DEVICE\_STATUS and the status on the Local Display on the transmitter. Note that BLOCK\_ERR will have bit 0 set whenever XD\_ERROR is non-zero. The DEVICE\_STATUS item indicates priority from lowest (0) to highest (11).

### 2.3.1.1 Transducer Block Priority

Block_Err	XD_Error	PV Quality	PV Quality Sub-status	DEVICE_STATUS ITEM	DEVICE_STATUS Description	Local Display
No bits set	0	Good NC	Non-Specific	0	OK	Status OK
No bits set	0	Uncertain	Sub normal	1	OK?	Status OK?
Bit 4 Local Override	0	Uncertain	Sub normal	2	USER MODE	User Mode
Bit 14 Power up	0	Uncertain	Initial Value	5	INITIALIZING	Initial
No bits set	0	Uncertain	Sensor conversion not accurate	3	DRY PROBE	Dry Probe
No bits set	0	Uncertain	Sensor conversion not accurate	4	POSSIBLY FLOODED PROBE	Flooded Probe
Bit 0 Other Bit 6 Needs Maint. Soon	18 Calibration Error	Uncertain	Configuration Error	6	NEEDS CALIBRATION	Out of Calib
Bit 0 Other Bit 11 Lost NV Data Bit 13 Needs Maint Now	18 Calibration Error	Bad	Configuration Error	10	PARAMETERS DEFAULTED	Corrupt Parmters
Bit 1 Config Error Bit 13 Needs Maint Now	0	Bad	Configuration Error	7	PARAMETERS INCORRECT	Bad Cal Parmters
Bit 0 Other Bit 7 Input Failure Bit 13 Needs Maint Now	21 Mechanical Failure	Bad	Device Failure	9	NO FIDUCIAL SIGNAL	No Fiducial
Bit 0 Other Bit 7 Input Failure Bit 13 Needs Maint Now	21 Mechanical Failure	Bad	Sensor Failure	8	NO LEVEL SIGNAL	No Level Signal
Bit 4 Local Override	0	Bad	Configuration Error	11	FACTORY MODE	Factory Mode

---

### 2.3.2 Password Parameters

CONFIG\_DIALOG, CONFIG\_VALUE, and CONFIG\_METHOD are used to:

- a. enter passwords,
- b. change the user password, and
- c. determine if the transmitter is in a password accessible state

The Eclipse Model 705 transmitter has a fixed factory password along with a user selectable password (default value of 1). The factory password is for use by trained factory personnel only. To change a parameter at the local user interface, a value matching either the factory password or the user password must be entered. If the user password is entered, the instrument is in the user mode. After 5 minutes with no keypad activity, the entered password expires, canceling either the user mode or the factory mode if either was active.

From the network, the instrument always behaves as if it is in the user mode by default. In other words, it is not necessary to enter the user password in order to write a user parameter from the network. To write a factory parameter from the network, the instrument must be put into the factory mode by entering the factory password into CONFIG\_VALUE and selecting "FACTORY\_PASSWORD" from CONFIG\_METHOD. The effect on the instrument is the same as if the factory password had been entered from the local user interface. While in the factory mode, the LCD on the transmitter will display a Status of "Factory Mode."

CONFIG\_VALUE is used for inputting and outputting numeric values. Password entries are numeric input values. Encrypted password is a numeric output value. The default value is the encrypted user password.

CONFIG\_METHOD is used to send commands to the transmitter. The possible commands are USER PASSWORD, FACTORY PASSWORD, and CHANGE PASSWORD. The default value is USER PASSWORD.

The relationship between the local user interface and the network for write access to parameters is explained in the table below. The effect of entering a password from either interface is the same.

Entered Password	LCD (Local Interface)	CONFIG_DIALOG
user password	User Mode	USER_ACCESS_ACTIVE
factory password	Factory Mode	FACTORY_ACCESS_ACTIVE
neither	OK	USER_ACCESS_ACTIVE

---

CONFIG\_DIALOG is used for outputting information from the transmitter. It has three values:

CONFIG_DIAG	Description
USER ACCESS ACTIVE	Default value
FACTORY ACCESS ACTIVE	Displayed while the transmitter is in factory mode
ACCESS REFUSED	Response to CHANGE_PASSWORD with CONFIG_VALUE out of range Response to FACTORY_PASSWORD with CONFIG_VALUE not equal to the factory password

### 2.3.2.1 Procedure for Changing User Password

Enter the desired new password in CONFIG\_VALUE and select "CHANGE\_PASSWORD" from CONFIG\_METHOD.

If the value is in range (0 to 255), CONFIG\_DIALOG remains "USER\_ACCESS\_ACTIVE" and CONFIG\_METHOD remains "CHANGE\_PASSWORD." Thirty seconds after the password is changed, CONFIG\_VALUE switches from plain text to an encrypted version of the new user password and CONFIG\_METHOD reverts to "USER\_PASSWORD."

If the value is out of range, CONFIG\_DIALOG switches to "ACCESS\_REFUSED" and CONFIG\_METHOD remains "CHANGE\_PASSWORD." After thirty seconds, CONFIG\_VALUE reverts to the encrypted display of the old user password, CONFIG\_DIALOG switches to "USER\_ACCESS\_ACTIVE" and CONFIG\_METHOD switches to "USER\_PASSWORD."

### 2.3.2.2 Displaying the User Password

Select "USER\_PASSWORD" from CONFIG\_METHOD. CONFIG\_DIALOG displays "USER\_ACCESS\_ACTIVE," CONFIG\_VALUE shows the encrypted value of the current user password, and CONFIG\_METHOD displays "USER\_PASSWORD." Factory mode, if active, is cancelled.

NOTE: If this action is performed while the default values are displayed, nothing appears to happen.

### 2.3.2.3 Password Operations

Action	CONFIG_DIALOG	CONFIG_VALUE	CONFIG_METHOD
Default	USER_ACCESS_ACTIVE	User password (encrypted)	USER_PASSWORD
Change user password (value in 0–255 range)	USER_ACCESS_ACTIVE	New user password (plain text)	CHANGE_PASSWORD
30 second time-out after changing user password	USER_ACCESS_ACTIVE	New user password (encrypted)	USER_PASSWORD
Change user password (value out of range)	ACCESS_REFUSED	Out of range password (plain text)	CHANGE_PASSWORD
30 second time-out after entering out of range password	USER_ACCESS_ACTIVE	Old user password (encrypted)	USER_PASSWORD
Enter correct factory password	FACTORY_ACCESS_ACTIVE	Factory password (encrypted)	FACTORY_PASSWORD
Exit from factory mode (5 minute time-out with no activity at local display)	USER_ACCESS_ACTIVE	User password (encrypted)	USER_PASSWORD
Enter incorrect factory password	ACCESS_REFUSED	Incorrect factory password (plain text)	FACTORY_PASSWORD
30 second time-out after entering incorrect factory password	USER_ACCESS_ACTIVE	Old user password (encrypted)	USER_PASSWORD
Put transmitter into factory mode from local interface	FACTORY_ACCESS_ACTIVE	User password (encrypted)	USER_PASSWORD

### 2.3.3 Primary Value (PV) Parameters

**PRIMARY\_VALUE\_TYPE:** The primary value type for the Eclipse Model 705 is Level. The corresponding value for this parameter is 110.

**PRIMARY\_VALUE:** an array containing the value of the level, the status of the measurement, and the limit condition. The PRIMARY\_VALUE is displayed in the units defined in PRIMARY\_VALUE\_RANGE.

**PRIMARY\_VALUE\_RANGE:** an array that defines the range of the PRIMARY\_VALUE, the units of the PRIMARY\_VALUE, and the decimal point position (number of significant digits to the right of the point). All the parameters in the array are read only. They are set from the Analog Input block (section 2.4) whenever XD\_SCALE is adjusted.

NOTE: The engineering units supported are meters, centimeters, feet, or inches. The decimal position is fixed at one.

### 2.3.4 Eclipse Model 705 Configuration Parameters

This set of parameters is important in the fact that they are the parameters required to configure every Eclipse Model 705 transmitter. Refer to I/O Manual 57-600 for more detailed information regarding the Model 705 transmitter.

**PROBE\_TYPE:** Select the choice that corresponds to the first four digits of the model number of the probe. An “x” in the selection means that character is variable (the probe model number is shown on the nameplates attached to both the transmitter and probe). For example, 7xA-x should be chosen for probe models beginning with 7EA or 7MA.

The last four selections in this list of probes are placeholders for future probes. If an unsupported probe type is selected, the transmitter will give a negative response and the value displayed will revert to its previous value.

**PROBE\_MOUNT:** Select the type of mounting on the probe. The choices are NPT, BSP, and Flange.

The last selection is a placeholder for a possible future addition. If an unsupported probe mount is selected, the transmitter will give a negative response and the value displayed will revert to its previous value.

**PROBE\_LENGTH:** Enter the exact length of the probe. The probe length is shown as the last three digits of the probe model number printed on the nameplates attached to the transmitter and probe. PROBE\_LENGTH is shown in CAL\_UNITS.

**LEVEL\_OFFSET:** Enter the distance from the probe tip to the desired 0% reference in CAL\_UNITS. The acceptable range is from -24 inches to 600 inches. Changing the LEVEL/OFFSET might cause an AI Block\_ERROR if the existing AI XD\_SCALE.EU\_100 or XD\_SCALE\_EU\_0 value would be off the new measurable range of the probe. Correct this problem by changing the AI XD\_SCALE.EU\_100 or XD\_SCALE\_EU\_0 value.

**DIELECTRIC\_RANGE:** Select the range covering the dielectric of the medium being measured. The choices are 1.4–1.7, 1.7–3.0, 3–10, and 10–100.

NOTE: All dielectric ranges are not available with all probes.

**THRESHOLD:** The threshold can be set as either FIXED or CFD. The factory default is CFD. This parameter should only be changed to FIXED in those applications having a lower dielectric material over a higher dielectric material. A typical example for FIXED Threshold is a hydrocarbon application having water bottoms.

Refer to I/O Manual 57-600 for additional information.

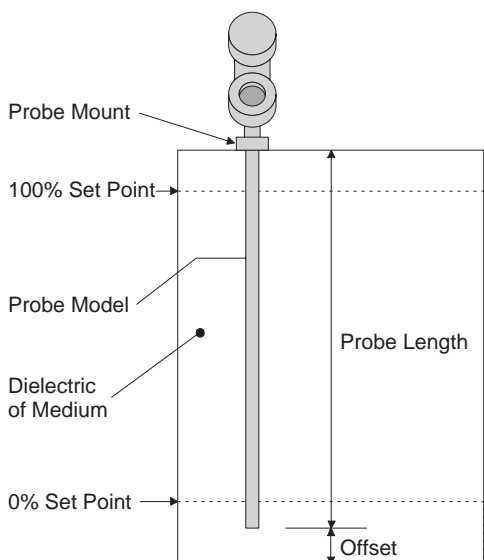

---

### 2.3.5 Calibration Parameters

One of the advantages of the Eclipse Model 705 GWR transmitter is that the device is calibrated at the factory, thus eliminating the need for field calibration. Every Eclipse Model 705 is shipped from Magnetrol factory calibrated. To coincide with this, part of the advantage of Fieldbus is the ability to monitor and track changes and adjustments to the transmitter. If a user believes it is necessary to make calibration adjustments, the following set of parameters give the user the ability to do a field calibration.

NOTE: The original factory calibration is maintained in this process, therefore the user can revert back to the factory calibration parameters at any time.

**SENSOR\_CAL\_METHOD:** Selection switch between the Factory and User measurement calibration parameters. The selections for this parameter are “Factory calibration active” or “User calibration active.” If “Factory calibration active” is chosen, the factory calibration parameters are displayed and used. If these factory calibration parameters are at the default values, the device indicates either “Corrupt Parameters” (DEVICE\_STATUS 11) if the device has once been calibrated but the parameters are now corrupted or “Out of Calib” (DEVICE\_STATUS 6) if the device has never been calibrated. If “User calibration active” is chosen, the user calibration parameters are displayed and used provided a user calibration has been completed successfully. Otherwise the factory calibration parameters are displayed and used and the device indicates “Out of Calib” with Quality Uncertain and Sub-status “Sensor conversion not accurate.”

**SENSOR\_CAL\_LOC:** contains the last calibration location. The device will be shipped with an entry of Factory. When the user does a calibration, an entry must be made here.

**SENSOR\_CAL\_DATE:** contains the date of the last calibration. The device will be shipped from the factory with the calibration date entered. When the user performs a calibration, an entry must be made here. The user entry should be the default clock time in the device, which should be synchronized with the system time and consequently the present time and date.

**SENSOR\_CAL\_WHO:** identifies the person who last calibrated the device. The device will be shipped from the factory with a technician’s ID. When the user does a calibration, an entry must be made here.

---

**CAL\_UNIT:** contains the user selectable engineering units for calibrating the device. It is the units chosen for CAL\_POINT\_HI, CAL\_POINT\_LO, CAL\_MIN\_SPAN, PROBE\_LENGTH and LEVEL\_OFFSET. The supported units are inches, feet, centimeters, and meters, with the default being inches.

**CAL\_MIN\_SPAN:** defines the absolute minimum span between CAL\_POINT\_HI and CAL\_POINT\_LO. The value is 6 inches for the Eclipse Model 705.

**CAL\_POINT\_HI:** During field (user) calibration when the liquid in the vessel is at a known high level, the user enters the desired level reading into CAL\_POINT\_HI in CAL\_UNITS. The transmitter captures LEVEL\_TICKS and CAL\_POINT\_HI. The written level value is checked for a span violation against CAL\_MIN\_SPAN. Refer to Section 2.3.5.1 below for more information.

**CAL\_POINT\_LO:** During field (user) calibration when the liquid in the vessel is at a known low level, the user enters the desired level reading into CAL\_POINT\_LO in CAL\_UNITS. The transmitter captures LEVEL\_TICKS and CAL\_POINT\_LO. The written level value is checked for a span violation against CAL\_MIN\_SPAN. Refer to Section 2.3.5.1 below for more information.

#### 2.3.5.1 GWR Transducer Field User Calibration

The Model 705 transmitter maintains a set of factory protected calibration parameters. Entered at the time of manufacture, these parameters are not field-adjustable.

Alternatively, a field calibration can be stored in a set of user calibration parameters. The choice of which calibration parameters are used for calculating level (factory or user) is determined by selecting the operation mode from the SENSOR\_CAL\_METHOD menu.

NOTE: The block MODE must be O/S (out of service) to change any user calibration parameters.

When SENSOR\_CAL\_METHOD is “Factory calibration active,” the factory calibration parameters are displayed and used.

When SENSOR\_CAL\_METHOD is “User calibration active,” the user calibration parameters are displayed and used provided a proper user calibration procedure has been performed. If a proper user calibration has not been performed, the factory calibration parameters are displayed and used, and the instrument indicates “Out of Calib.”

---

A user calibration is accomplished by moving the level to a known position and entering the desired level reading at that position, either CAL\_POINT\_HI or CAL\_POINT\_LO. This action can only be performed when SENSOR\_CAL\_METHOD is selected as "User calibration active." The transmitter will capture the corresponding LEVEL\_TICKS reading at the moment the CAL\_POINT is written. Initially this procedure must be performed at two levels, high and low, separated by at least 6 inches (152 mm). The user points can be calibrated in either order, but until both cal points are calibrated, the instrument remains in the "Out of Calib" condition with Quality Uncertain and Sub-status "Sensor conversion not accurate." While either or both user points are uncalibrated, the factory calibration parameters are displayed and used to calculate level. (An uncalibrated CAL\_POINT has a value of -100.0 inches).

Once both CAL\_POINT\_LO and CAL\_POINT\_HI have been calibrated, the instrument calculates the user calibration parameters, stores, displays and uses these parameters for calculating level. The "Out of Calib" condition will change to "OK" with associated Quality and Sub-status.

Either CAL\_POINT can be recalibrated at any time. If the recalibration does not produce a span violation, the user calibration parameters are recalculated, stored, displayed and used to calculate level. If the recalibration of a CAL\_POINT results in a span violation the other CAL\_POINT is forced to the uncalibrated value of -100.0 inches, the user calibration parameters are voided and the instrument reverts to the "Out of Calib" condition with Quality Uncertain and Sub-status "Sensor conversion not accurate."

Similarly, if either PROBE\_TYPE or PROBE\_MOUNT are changed, both CAL\_POINTS are forced to the uncalibrated value, the user calibration parameters are voided and the instrument reverts to the "Out of Calib" condition with Quality Uncertain and Sub-status "Sensor conversion not accurate."

NOTE: As the Model 705 has four ranges of operation, and therefore, four sets of calibration parameters. If PROBE\_LENGTH is changed enough to move it into another range of operation, both CAL\_POINTS are forced to the uncalibrated value, the user calibration parameters are voided.

The values displayed for CONVERSION\_FACTOR and SCALE\_OFFSET are those presently being used to calculate level.

---

*User calibration has no effect on factory calibration values. CAL\_POINT\_HI and CAL\_POINT\_LO will always display the last value written.* Prior to the first user calibration, these parameters will have a value of -100.0 inches to indicate that neither point has been calibrated.

*SENSOR\_CAL\_METHOD can be switched between Factory and User at any time.* The state of the instrument may change as a result if either of the calibrations is uncertain.

### 2.3.6 Factory Parameters

The six factory calibrated parameters are RANGE, GAIN, WINDOW, CONVERSION\_FACTOR, SCALE\_OFFSET.

RANGE, GAIN and WINDOW are used to adjust for the variations in the analog section of the Eclipse TDR measurement engine. CONVERSION\_FACTOR and SCALE\_OFFSET are the main factory calibration settings. These two parameter values are saved in a table for the four different ranges of operation. The correct set of these two calibration values are internally selected by the value of PROBE\_LENGTH as set by the user. This parameter should not be changed in the field and, for that reason, is protected by a factory password.

The following parameters are used for either troubleshooting or are parameters adjusted at the factory. They should never be changed in the field.

**RANGE:** determines the maximum distance along the probe for which signals are scanned. This is a read only parameter determined by PROBE\_LENGTH.

**GAIN:** determines the amplifier gain applied to the signal reflected from the surface of the product being measured.

**WINDOW:** determines the amount of delay between the generation of the transmitted signal pulse and the start of the measurement cycle.

**FID\_TICKS:** a measure of the time to the fiducial (reference) pulse.

**FID\_TICKS\_SPREAD:** provides an indication of the stability of the FID\_TICKS measurement.

**LEVEL\_TICKS:** a measure of the time to the level of the product being measured.

**LEVEL\_TICKS\_SPREAD:** provides an indication of the stability of the LEVEL\_TICKS measurement.

**CONVERSION\_FACTOR:** the slope of the calibration line.

**SCALE\_OFFSET:** the intercept of the calibration line.

---

### 2.3.7 Miscellaneous Sensor Parameters

The next three parameters give additional sensor information.

**SENSOR\_TYPE:** TDR Level. The value is 150.

**SENSOR\_RANGE:** a read-only parameter that has the value of PROBE\_LENGTH.

**SENSOR\_SN:** A unique number assigned at the factory and is related to the Magnetrol customer order number.

### 2.3.8 Discrete Switch Parameters

The GWR TRANSDUCER block has two discrete outputs which are configured with eight parameters and instantiated at the factory.

The first discrete input (DI) block is assigned to PRIMARY\_VALUE\_D1 and has a channel value of 1. The second DI block is assigned to PRIMARY\_VALUE\_D2 and has a channel value of 2. Once both blocks are instantiated, the channels can not be reassigned. Only two DI blocks can be instantiated. If the user deletes the two DI blocks and then instantiates only one DI block, that block can be connected to either PRIMARY\_VALUE\_D1 or PRIMARY\_VALUE\_D2 by assigning the DI channel as 1 or 2, respectively.

**PRIMARY\_VALUE\_D1:** the first discrete output. It is either Inactive or Active.

**PRIMARY\_VALUE\_D1\_FILTER:** selects the action that will determine the state of the discrete output (the list of actions is identical for D1 and D2).

**FILTER: PV>SP:** When the Primary Value rises above the Set Point, the discrete output switches from Inactive to Active. When the Primary value falls below the value of (SP-Band), the discrete output switches back to Inactive.

**FILTER: PV<SP:** When the Primary Value falls below the Set Point, the discrete output switches from Inactive to Active. When the Primary value rises above the value of (SP+Band), the discrete output switches back to Inactive.

**FILTER: PV=SP:** When the Primary Value reaches the Set Point from either direction, the discrete output switches from Inactive to Active. When the Primary value rises above (SP+Band) or falls below (SP-Band), the discrete output switches back to Inactive.

---

**FILTER: POSSIBLY FLOODED PROBE:** The discrete output is only Active while the transducer block is indicating a possibly flooded probe.

**FILTER: DRY PROBE:** The discrete output is Active only while the transducer block is indicating a dry probe.

**PRIMARY\_VALUE\_D1\_SP:** the set point where the discrete output switches state. It is expressed in PRIMARY\_VALUE\_RANGE units.

**PRIMARY\_VALUE\_D1\_BAND:** defines the hysteresis region about the set point. It is expressed in PRIMARY\_VALUE\_RANGE units.

**PRIMARY\_VALUE\_D2:** the second discrete output. It is either Inactive or Active.

**PRIMARY\_VALUE\_D2\_FILTER:** selects the action that will determine the state of the discrete output. The list of actions is identical for D1 and D2. Refer to PRIMARY\_VALUE\_D1\_FILTER above for the list of actions.

**PRIMARY\_VALUE\_D2\_SP:** the set point where the discrete output switches state. It is expressed in PRIMARY\_VALUE\_RANGE units.

**PRIMARY\_VALUE\_D2\_BAND:** defines the hysteresis region about the set point. It is expressed in PRIMARY\_VALUE\_RANGE units.

### 2.3.9 Firmware Version ---

The last parameter in the TRANSDUCER block gives the firmware version of the transmitter.

**MODEL\_FWV:** displays the version of the firmware in the transmitter.

NOTE: The user should compare the DD file and revision number of the device with the HOST system to ensure they are at the same revision level.

## 2.4 Analog Input Block

The ANALOG INPUT (AI) block takes the analog PV\_VALUE from the TRANSDUCER block and makes it available to the other function blocks. The CHANNEL parameter must be set to 1 if the AI block is running. The TRANSDUCER and AI block's MODE\_BLK parameter must be set to AUTO to pass the Transducer Level through the AI to the network.

Transducer scaling, XD\_SCALE, is applied to the level from the CHANNEL to produce the FIELD\_VAL in percent. Valid XD\_SCALE in engineering units is limited to the four allowable codes of meters (m), centimeters (cm), feet (ft), and inches (in) in the TRANSDUCER range parameters.

**Range limits must be located on the probe, otherwise a block alarm indicating configuration error will be generated.**

In other words, The AI block XD\_RANGE "EU at 100%" must be less than or equal to the TRANSDUCER PROBE\_LENGTH plus the LEVEL\_OFFSET and the AI block XD\_RANGE "EU at 0%" must be greater than or equal to the TRANSDUCER LEVEL\_OFFSET. When either of these values is not on the probe, the AI block will have a BLOCK\_ERR. See drawing at left.

The L\_TYPE parameters determine how the AI block modifies the TRANSDUCER level value:

When L\_TYPE is DIRECT the LEVEL is passed unmodified by XD\_SCALE.

When L\_TYPE is INDIRECT the LEVEL is XD\_SCALE value converted by OUT\_SCALE.

When the L\_TYPE is INDIRECT\_SQRT the LEVEL is the square root of XD\_SCALE value converted by OUT\_SCALE.

AI PV and OUT parameters always have identical scaling based on OUT\_SCALE.

The LOW\_CUT parameter is used for flow sensors and should be disabled (false).

The AI can have a BLOCK\_ERR when:

1. CHANNEL and L\_TYPE parameters have an invalid value
2. XD\_SCALE does not have suitable engineering units or has range incompatibility.
3. SIMULATE parameter is active
4. AI block MODE is O/S (out of service).

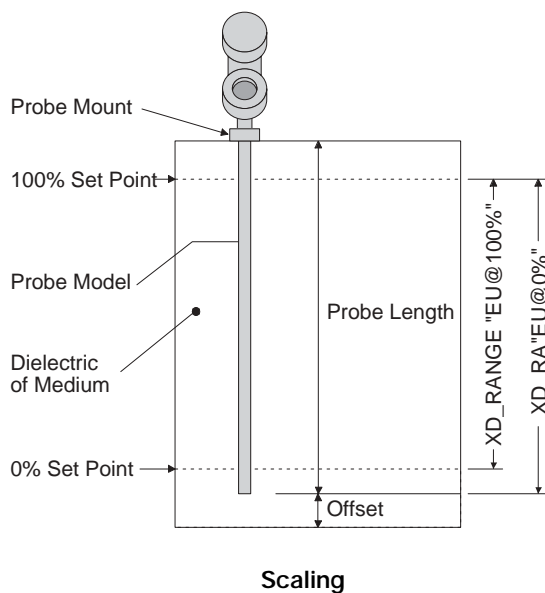

---

When the OUT value exceeds the OUT\_SCALE range and no worst condition exists in the block, the OUT status will be “Uncertain, EU Range Violation.”

The AI uses the STATUS\_OPTS setting and the TRANSDUCER PV LIMIT value to modify the AI PV and OUT QUALITY.

For Propagate Fault Forward, the TRANSDUCER QUALITY will propagate unmodified.

For Uncertain if Limited, the QUALITY could be changed to Uncertain if LIMITED.

For BAD if Limited, the QUALITY will change to BAD if LIMITED.

For Uncertain if Man mode, the QUALITY is Uncertain if in Manual Mode.

Damping Filter is a feature of the AI block. PV\_FTIME parameter is time constant of a single exponential filter for the PV, in seconds. This parameter can be used to dampen out fluctuation in level due to excessive turbulence.

The AI block has multiple ALARM functions that monitor the OUT parameter for out of bound conditions.

## 2.5 Discrete Input Block

The DISCRETE INPUT block takes PV\_VALUE\_D1 and/or PV\_VALUE\_D2 from the TRANSDUCER block and makes them available to other function blocks. The CHANNEL parameter must be set to 1 for the first discrete output or 2 for the other. The TRANSDUCER block must be configured to select the desired discrete logic function.

Using XD\_STATE, the FIELD\_VAL\_D shows the true on/off state of the hardware. The invert I/O option can be used to do a Boolean Not function between the TRANSDUCER value and the output. A discrete value of zero (0) will be considered to be a logical zero (0) and a non-zero discrete value will be considered to be a logical one (1). If invert is selected, the logical NOT of a non-zero field value would result in a zero (0) discrete output, the NOT of a zero field value would result in a discrete output value of one (1). PV\_FTIME may be used to set the amount of time that the hardware must be in a given state before it gets passed to the PV\_D. OUT\_D is PV\_D when the MODE is AUTO and can be written to when the MODE is set to MAN. The PV\_D and OUT\_D always have identical scaling. OUT\_STATE provides scaling for PV\_D.

---

The DI block has multiple ALARM functions that monitor the OUT\_D parameter for out of bound conditions.

The DI CHANNEL parameter must be 1 (one) or 2 (two).

The Transducer and DI blocks MODE\_BLK must be set to AUTO to pass the Transducer Level through the DI to the network.

The TDR TRANSDUCER discrete logic function is selected from the PRIMARY\_VALUE\_DX\_FILTER menu. The digital logic set point value is in PRIMARY\_VALUE\_DX\_SP. The discrete logic hysteresis value is in PRIMARY\_VALUE\_DX\_BAND.

Damping out fluctuating in the level is done by setting the PV\_FVTIME in the DI block.

The DI can have a BLOCK\_ERR when:

1. CHANNEL has an invalid entry.
2. SIMULATE parameter is active.
3. DI block MODE is set to O/S.

The DI uses the STATUS\_OPTS setting and the TRANSDUCER PV LIMIT value to modify the DI PV\_D and OUT QUALITY.

For Propagate Fault Forward, the TRANSDUCER QUALITY will be propagated unmodified.

For Uncertain if Limited, the QUALITY could be change to Uncertain if LIMITED.

For BAD if Limited, the QUALITY will change to BAD if LIMITED.

For Uncertain if Man mode, the QUALITY is Uncertain if in Manual Mode.

Damping Filter is a feature of the DI block. The PV\_FTIME parameter is a time constant of a single exponential filter for the PV\_D (in seconds).

---

## 2.6 PID Block

The PID block uses Proportional, Integral and Derivative terms to control processes. The PID input could be any process variable that is available on the network. It does not have to originate from the Model 705 AI or DI blocks.

The algorithm of the PID is the non-iterative or ISA. In this algorithm, the GAIN is applied to all terms of the PID. The proportional and integral actuate over the error, and the derivative actuates over the PV value. Therefore, user changes of SP? will not cause changes in the output due to the derivative term when the block is in Auto.

As long as an error exists, the PID function will integrate the error, forcing the output in a direction to correct it.

NOTE: PID blocks may be cascaded when the difference in process time constants of a primary and secondary measurement makes it necessary or desirable.

Direction of action is selectable by changing the CONTROL\_OPTS “Direct Acting” bit. When “true,” the error is PV minus the set point. When “false,” the error is set point minus PV.

The PID supports the feed forward algorithm. The FF\_VAL input is supplied by an external value, which is proportional to some disturbance in the control loop. The value is converted to output scale using the FF\_SCALE and OUT\_SCALE parameters. The value is then multiplied by FF\_GAIN and added to the output of the PID algorithm. If the status of FF\_VAL is BAD, the last usable value will be used. When the status returns to GOOD, the difference of FF\_VAL values will be subtracted from BIAS\_A/M in order to avoid a momentary change in the output.

GAIN (K<sub>p</sub>), RESET (T<sub>r</sub>) and RATE (T<sub>d</sub>) are the tuning constants for the P, I and D terms, respectively. Gain is a dimensionless number. RESET and RATE are time constants in seconds.

When bypass is active the SP value will be transferred to the OUT without calculation of the PID terms. Bypass is used in a secondary cascade controller when the PV is bad. The CONTROL\_OPTS “Bypass Enable” bit must be true. BYPASS parameter is changed to ON.

The BYPASS parameter is the ON/OFF switch that activates the bypass. By default, it can be changed only when the block mode is MAN or O/S. Optionally, when the FEATURE\_SEL parameter “Change of Bypass in an automatic mode” bit is true, then the block permits BYPASS switch changes in automatic modes too.

There is special treatment when the Bypass parameter changes ON/OFF in order to avoid momentary changes in the output. When the bypass is switched to ON, the SP receives the OUT value in percent of the OUT\_SCALE. When the bypass is switched to OFF, the SP receives the PV value.

The PID block supports the output tracking algorithm, which allows the output to be forced to a tracking value when the tracking switch is on. To activate the output tracking in an “automatic” mode (Auto, Cas and Rcas) or Rout the CONTROL\_OPTS bit must be true and the TRK\_IN\_D value is active. Also the TRK\_VAL and TRK\_IN D QUALITY is good unless the “Use Uncertain as good” bit in STATUS\_OPTS is true, then uncertain is valid state for tracking in an “automatic” mode.

For tracking in Man mode the above conditions must be met and the “Track in Manual” bit in CONTROL\_OPTS must be true. When the output tracking is active in the Man mode, the output OUT will be replaced by the TRK\_VAL converted to OUT\_SCALE. The output limit attribute becomes Constant and the actual mode goes to LO. If the TRK\_IN\_D or TRK\_VAL status is unusable, the Output tracking will be off and the PID will return to normal operation.

The PID block has multiple ALARM functions that monitor the OUT parameter for out of bound conditions.

### 3.0 Configuring the Level Transmitter

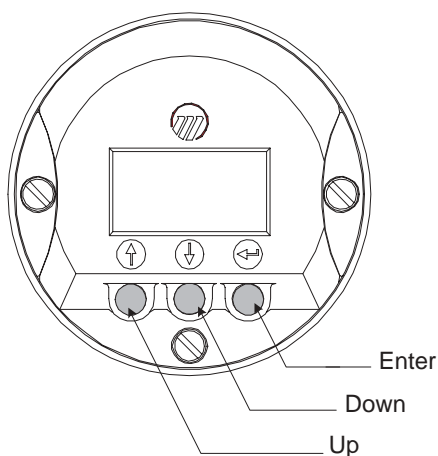

The Eclipse Model 705 transmitter is shipped calibrated from the factory. Simple configuration, which can be performed on a bench in the instrument shop without being connected to the Fieldbus network, is all that is required by the user. Bench configuration with the device connected to a non-process connected Fieldbus power conditioner and terminator provides a convenient and efficient way to set up the transmitter for a given application before going to the tank site to complete the installation.

NOTE: If connected to the network, changing the transmitter configuration affects the PV\_VALUE. These parameters are protected by requiring that the device MODE is set to O/S before any changes are accepted.

The setting of the ANALOG INPUT (AI) blocks affects the configuration parameters such as TRANSDUCER dimension units PRIMARY\_VALUE\_RANGE.

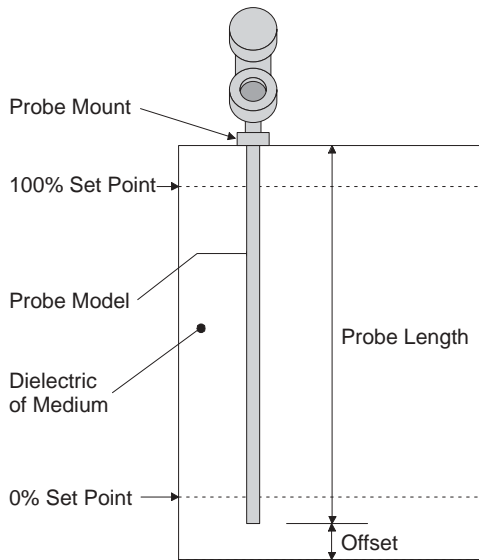

UNITS\_INDEX is a read-only parameter attribute that is the same as the AI XD\_SCALE.UNIT\_INDEX. The AI and TRANSDUCER blocks will both show a block error if the AI XD\_SCALE\_EU\_100 or XD\_SCALE\_EU\_0 value are not set within the measurable range of the probe.

Reconfiguration is a simple process which consists of only changing those parameters which differ from the target configuration (refer to I/O Manual 57-600 for further information regarding customer configuration).

1. Select the correct probe from the PROBE\_TYPE menu.
2. Select the type of probe mount from the PROBE\_MOUNT menu.
3. Enter the exact length of the probe in PROBE\_LENGTH.
4. Select the most suitable dielectric range from the DIELECTRIC\_RANGE menu.

## 4.0 Diagnostic Parameters

The Eclipse Model 705 GWR measurement engine runs through a series of self-tests and will detect and report faulty operation. The GWR TRANSDUCER BLOCK displays these faults in BLOCK\_ALM and XD\_ERROR. Faulty operation information is passed to the AI or DI block through the PV\_VALUE.STATUS and PV\_VALUE\_DX.STATUS attributes respectively. The AI and DI maintain all QUALITY and LIMIT attributes, but converts all specific error SUB\_STATUS to “Non-Specific.”

When the Model 705 transmitter is initially powered on, the measurement engine does not have enough valid measurement cycles to make a decision about the output level. For the first sixteen measurement cycles after power is applied, the Transducer output is fixed to LEVEL\_OFFSET, the QUALITY is “Uncertain”, and the SUB\_STATUS is “Initial value.” In addition, the LIMIT attribute is “Constant”, BLOCK\_ERR bit “Power Up” is set, and XD\_ERR remains cleared.

When the Model 705 is operating correctly, the QUALITY is shown as “GOOD”, and the SUB\_STATUS is “Non-Specific.” The LIMIT attribute is “Not Limited” unless the PV (primary variable) value is at the top or bottom of the probe. If so, the LIMIT attribute is shown as “High Limited” and “Low Limited” respectively. BLOCK\_ERR and XD\_ERR are cleared.

While changing the transmitter operational parameters using the local display (with a user or factory password) or through the system configuration tool (with the MODE\_BLK in O/S), the output might be inaccurate

---

because of the changing parameters. When the device is in a mode where operational parameters can be changed, the GWR TRANSDUCER BLOCK will still output level. The QUALITY is shown as “Bad” and the SUB\_STATUS is “Out of Service.”

The block will report a fault until the Factory Password has timed out, even after the MODE has been returned to AUTO. While the device is in this mode, the GWR Transducer will still output level. The QUALITY is “Bad”; the SUB\_STATUS is “Configuration error.”

If the Model 705 loses calibration data, the transmitter will still output a level using generic default values for CONVERSION\_FACTOR and SCALE\_OFFSET. The QUALITY will be shown as “Bad”, the SUB\_STATUS as “Configuration error.” BLOCK\_ERR “Other”, “Lost NV Data” and “Need Maint Soon” bits are set. XD\_ERR becomes “Calibration Error.”

When the Model 705 measurement cycle fails to find a valid output level, the transmitter maintains the last good value as the output and flags the failure. If the Model 705 has a few disrupted measurement cycles, the QUALITY is shown as “Uncertain” and the SUB\_STATUS is “Sub Normal.” The LIMIT attribute is the same as the last good measurement. BLOCK\_ERR and XD\_ERR remained cleared. Excessive disrupted cycles causes the transmitter to go into a defined operational mode based on the cause of the disrupted cycles.

When the Model 705 detects a level above the highest measurement point of the probe the operational mode is shown as FLOODED\_PROBE. Since the actual level location above the top of the probe is not known, the output is not accurate. The GWR TRANSDUCER BLOCK output is calculated as LEVEL\_OFFSET plus PROBE\_LENGTH. The QUALITY is “Uncertain” and the SUB\_STATUS is “Sensor conversion not accurate.” The LIMIT attribute is “High\_Limited.” BLOCK\_ERR and XD\_ERR are cleared.

The Model 705 operational mode is DRY\_PROBE when the level is below the end of the probe. Again, the output is not accurate, since the location of the level below the end of the probe is not known. The GWR TRANSDUCER BLOCK output is calculated as LEVEL\_OFFSET. The QUALITY is “Uncertain” and the SUB\_STATUS is “Sensor conversion not accurate.” The LIMIT attribute is “Low\_Limited.” BLOCK\_ERR and XD\_ERR are cleared.

When in the dry probe condition, the Model 705 compares the measured length of the probe to value entered into the PROBE\_LENGTH parameter. If the measured value does

---

not match PROBE\_LENGTH, a configuration fault is reported. The GWR TRANSDUCER BLOCK output is set to the LEVEL\_OFFSET. The QUALITY is “Bad.” The SUB\_STATUS is “Configuration error.” The LIMIT attribute is “Low Limited.” BLOCK\_ERR “Config Error” and “Need Maint Soon” bits are set. XD\_ERR is cleared.

If the Model 705 fails to find a measurable level, either due to an actual loss of a level signal or the loss of a proper Fiducial signal, the GWR TRANSDUCER BLOCK maintains the last good value as the output and flags the failure. The QUALITY is “Bad” and the SUB\_STATUS is “Sensor failure” for no level and “Device failure” for loss of the Fiducial. The LIMIT attribute is “Constant.” BLOCK\_ERR “Other”, “Config Error” and “Need Maint Soon” bits are set. XD\_ERR is Mechanical error.

#### 4.1 Simulation Feature

The Eclipse Model 705 with Foundation Fieldbus supports the Simulate feature in the Analog and Discrete blocks. The Simulate feature is typically used to exercise the operation of an AI block by simulating a TRANSDUCER block input.

This feature can not be activated without the placement of a hardware jumper. This jumper is installed as standard on the Eclipse Model 705, and is placed in an inconvenient location to avoid inadvertent disabling of this feature.

Contact the factory for instructions on how to remove this jumper and permanently disable the Simulate feature.

#### 5.0 Documentation

The following two tables are examples of data sheets describing what information is need to fully specify a Fieldbus device. The first table shows one device per page, while table 2 is intended for multiple devices.

Refer to “Foundation Fieldbus System Engineering Guidelines—AG-181” for additional information. This document can be found at **[www.fieldbus.org](http://www.fieldbus.org)**.

## 5.1 Fieldbus Data Sheet for Individual Instrument

Fieldbus Function Blocks	Segment Information	Miscellaneous Information
<input type="checkbox"/> Analog Input (AI) _____ Number _____ Execution Time (msec)	<input type="checkbox"/> Arithmetic (A) _____ Execution Time (msec)  <input type="checkbox"/> Digital Alarm (DA) _____ Execution Time (msec)	Device:  Segment # _____
<input type="checkbox"/> Discreet Input (DI) _____ Number _____ Execution Time (msec)	<input type="checkbox"/> Calculate _____ Execution Time (msec)  <input type="checkbox"/> Analog Alarm (AA) _____ Execution Time (msec)	LAS Capable: <input type="checkbox"/> YES <input type="checkbox"/> NO  Device current draw (mA):  In-rush current (mA):
<input type="checkbox"/> Bias/Gain Settings (BG) _____ Execution Time (msec)	<input type="checkbox"/> Deadtime (D) _____ Execution Time (msec)	Device Lift-off (minimum) voltage:
<input type="checkbox"/> Manual Loader _____ Execution Time (msec)	<input type="checkbox"/> Complex Analog Output (CAO) _____ Execution Time (msec)	Device capacitance:
<input type="checkbox"/> Proportional/Integral/Derivative (PID) _____ Execution Time (msec)	<input type="checkbox"/> Step Output PID (SOPID) _____ Execution Time (msec)	Polarity Sensitive: <input type="checkbox"/> YES <input type="checkbox"/> NO
<input type="checkbox"/> Analog Output (AO) _____ Number _____ Execution Time (msec)	<input type="checkbox"/> Set Point Ramp Generator _____ Execution Time (msec)	DD Revision:
<input type="checkbox"/> Discrete Output (DO) _____ Number _____ Execution Time (msec)	<input type="checkbox"/> Signal Characterizer (SC) _____ Execution Time (msec)	CFF Revision: Tested with ITK revision
<input type="checkbox"/> Control Selector (CS) _____ Execution Time (msec)	<input type="checkbox"/> Digital Human Interface (DHI) _____ Execution Time (msec)	NOTES:
<input type="checkbox"/> Proportional/Derivative (PD) _____ Execution Time (msec)	<input type="checkbox"/> _____ _____ Execution Time (msec)	
<input type="checkbox"/> Ratio _____ Number _____ Execution Time (msec)		

## 5.2 Fieldbus Data Sheet for Multiple Devices

TAG NUMBER	1	2	3	4	5	6	7	8	9	10	11	12
Number of AIs												
AI Execution Time (msec)												
Number of AOs												
AO Execution Time (msec)												
Number of SSSs												
SS Execution Time (msec)												
Number of TOTs												
TOT Execution Time (msec)												
Number of ARs												
AR Execution Time (msec)												
Number of PIDs												
PID Execution Time (msec)												
Number of _____												
Execution Time												
Number of _____												
Execution Time												
Number of _____												
Execution Time												
Number of _____												
Execution Time												
Number of _____												
Execution Time												
Number of _____												
Execution Time												
Channel												
I.S. Segment (If applicable)												
LAS Capable (Yes/No)												
DD Revision												
ITK Revision												
Polarity Sensitive (Yes/No)												
CFF Revision												

---

## 6.0 Reference Information

### 6.1 Troubleshooting

The Eclipse transmitter is designed and engineered for trouble-free operation over a wide range of operating conditions. Common transmitter problems are discussed in terms of their symptoms and recommended corrective actions. Information on how to handle material buildup on the probe is also provided in this section.

**WARNING!** Explosion hazard. Do not connect or disconnect equipment unless power has been switched off or the area is known to be non-hazardous.

#### 6.1.1 Troubleshooting System Problems

Symptom	Problem	Solution
LEVEL and % OUTPUT values are inaccurate.	Basic configuration data is questionable.	Reconfigure the Probe Model and/or Probe Mount, Probe Length or Offset. 1) Ensure the Level is accurate. 2) Verify 0% and 100% Loop values.
LEVEL readings are repeatable but consistently high or low from actual by a fixed amount.	Configuration data does not accurately match probe length or tank height.	Ensure proper Probe Model and probe length.
LEVEL and % OUTPUT values fluctuate.	Turbulence	Increase the Damping factor until the readings stabilize.
	High Frequency connection	Check Fid Ticks (should be stable within $\pm 10$ counts).
LEVEL and % OUTPUT values all reading low vs. actual.	Lower dielectric material over higher dielectric material, e.g. oil over water	Select Fixed Threshold option.
	Coating, clumping or buildup on probe	Expected inaccuracies due to affect on pulse propagation.
	Dense, water based foam	Expected inaccuracies due to affect on pulse propagation.
Level Reading on Display is stuck at full scale, % OUTPUT is stuck at 100%.	Software believes probe is flooded (level near very top of probe).	Check actual level. If probe is not flooded, Check for buildup or obstructions near top of probe. Select higher dielectric range.

NOTE: When consulting the factory concerning improper operation, use proper table on 44. Enter all data when transmitter is working CORRECTLY or INCORRECTLY.

## 6.1.2 Error Messages

Symptom	Problem	Solution
<b>NO FIDUCIAL</b>	Poor circuit board/cable/probe connection or malfunctioning cable between electronics and probe	Check all of the connections from the electronics to the probe.  Consult factory
<b>NO LEVEL SIGNAL</b>	Improper dielectric range chosen	Check dielectric of media vs. software choice. Select lower dielectric range.
	Dielectric too low for probe type	Confirm the probe choice is proper for the dielectric of the media.
	Malfunctioning analog board and/or 32 pin connector	Replace electronic module.  Consult Factory – verify Conversion Factor and Scale Offset values.
<b>CORRUPT PARAMTRS</b>	Internal parameters corrupted	Check all Configuration parameters.  Verify Probe Type and Probe Length.
Out of Calibration (not a fault)	Displayed when at least one parameter has been modified after corruption	Consult factory – Recalibration may be required.
<b>BAD CAL PARAMTRS</b>	Probe Length entered in software is not equal to value measured by electronics; possible media buildup on probe.	Verify Probe Length entered in software is correct.  Clean media off probe.
	Improper dielectric selected	Select proper dielectric range.

## 6.1.3 Troubleshooting Guide

### 6.1.3.1 FF Segment Checklist

There can be several reasons for a Foundation Fieldbus installation to be in a faulty condition. In order to assure that communication can be established, the following requirements must be met.

- Device supply voltage must be higher than 9 VDC with a maximum of 32 VDC.
- Total current draw of a given segment cannot exceed the rating shown on the power conditioner and/or barrier.
- Device polarity must be correct.
- Two 100  $\Omega$ , 1  $\mu$ F terminators must be connected to the network—one at each end of the segment.
- Cable length plus spur length must not exceed the following values:

Number of Spurs	1 Device	2 Devices	3 Devices	4 Devices
25–32	—	—	—	—
19–24	100 ft. (30 m)	—	—	—
15–18	200 ft. (60 m)	100 ft. (30 m)	—	—
13–14	300 ft. (90 m)	200 ft. (60 m)	100 ft. (30 m)	—
1–12	400 ft. (120 m)	300 ft. (90 m)	200 ft. (60 m)	100 ft. (30 m)

Pair	Shield	Twisted	Size	Length	Type
Single	Yes	Yes	AWG 18 (0.8 mm <sup>2</sup> )	6,200 ft. (1,900 m)	A
Multi	Yes	Yes	AWG 22 (0.32 mm <sup>2</sup> )	3,900 ft. (1,200 m)	B
Multi	No	Yes	AWG 26 (0.13 mm <sup>2</sup> )	1,300 ft. (400 m)	C
Multi	Yes	No	AWG 16 (1.25 mm <sup>2</sup> )	650 ft. (200 m)	D

- The cable shield is to be hard grounded only at one point close to the DCS. In addition, the cable shield can be capacitively grounded in multiple places to improve EMC protection.
- Ensure all devices are on the “live list,” and the schedule has been downloaded.
- Ensure the device identity is in the Resource Block.
- Ensure that the Resource Block, then the Transducer Block, and lastly the Function Block(s) are “on” rather than Out of Service (O/S).

If all of these requirements are met, a stable communication should be established.

## 6.2 Agency Approvals

AGENCY	MODEL APPROVED	APPROVAL CATEGORY	APPROVAL CLASSES	
	705-52XX-1XX 705-52XX-2XX	Intrinsically Safe	Class I, Div. 1; Groups A, B, C, & D Class II, Div. 1; Groups E, F, & G T4 Class III, Type 4X IP66 Entity/FISCO	
	705-52XX-3XX 705-52XXX-4XX	Explosion Proof ① (with Intrinsically Safe probe)	Class I, Div. 1; Groups B, C & D Class II, Div. 1; Groups E, F, & G T4 Class III, Type 4X IP66	
	705-52XX-XXX 705-52XX-XXX	Non-Incendive Suitable for: ②	Class I, Div. 2; Groups A, B, C, & D Class II, Div. 2; Groups F & G T4 Class III, Type 4X IP66	
		705-52XX-1XX 705-52XX-2XX	Intrinsically Safe	Class I, Div. 1; Groups A, B, C, & D Class II, Div. 1; Group G T4 Class III, Type 4X Entity/FISCO
		705-52XX-3XX 705-52XX-4XX	Explosion Proof ① (with Intrinsically Safe probe)	Class I, Div. 1; Groups B, C & D Class II, Div. 1; Group G T4 Class III, Type 4X
		705-52XX-XXX 705-52XX-XXX	Non-Incendive Suitable for: ②	Class I, Div. 2; Groups A, B, C, & D Class II, Div. 2; Group G T4 Class III, Type 4X
	705-52XX-AXX 705-52XX-BXX	Intrinsically Safe	Ⓜ II 1G, EEx ia IIC T4	
	705-52XX-CXX 705-52XX-DXX	Flame Proof ①	Ⓜ II 1/2G, EEx d [ia] IIC T4	
	705-52XX-EXX 705-52XX-FXX	Non-sparking ②	Ⓜ II 3G, EEx n II T4..T6	

① Factory Sealed: This product has been approved by Factory Mutual Research (FM), and Canadian Standards Association (CSA), as a Factory Sealed device.

② Measured media inside vessel must be non-flammable only.



These units are in conformity of:

1. The EMC Directive: 89/336/EEC. The units have been tested to EN 61000-6-2/2001 and EN 61000-6-4/2001.
2. Directive 94/9/EC for equipment or protective system for use in potentially explosive atmospheres.





## 6.3 Specifications

### 6.3.1 Functional

#### System Design

Measurement Principle                      Guided time-of-flight via time domain reflectometry

#### Input

Measured Variable                              Level, determined by the time-of-flight of a guided radar pulse from transmitter to product surface and back

Zero and Span                                    6" to 240" (15 to 610 cm)

#### User Interface

Keypad    3-button menu-driven data entry and system security

Indication                                         2-line × 8-character display

Digital Communication                         Foundation Fieldbus, H1 (31.25 kbits/sec)

Interoperability test kit (ITK Revision)    ITK 4.51

LAS capable                                      Yes, Device type: Linkmaster

Minimum Operating Voltage                    9 VDC

Quiescent Current Draw                        17 mA

DEV Revision                                     01

CF Revision                                      01

Channel

Function Blocks                                 AI\_1, DI\_1, DI\_2, PID\_1 to PID 19

#### Power (Measured at instrument terminals)

Fieldbus                      General Purpose/XP                      9–32 VDC (17 mA current draw)

Fieldbus                      IS/FISCO/FNICO                            9–30 VDC (17 mA current draw)

#### Housing

Material    Aluminum A356T6 (<0.20% copper), optional 316 stainless steel

Cable Entry                                        ¾" NPT, M20, PG13.5, PG16

#### Environment

Operating Temperature                        -40 to +175° F    (-40 to +80° C)

Display Function Operating Temperature    -5 to +160° F    (-20 to +70° C)

Storage Temperature                           -50 to +175° F    (-40 to +80° C)

Humidity     0-99%, non-condensing

Electromagnetic Compatibility               Meets CE Requirements: EN 50081-2, EN 50082-2 (Twin Rod and Single Rod probes must be used in metallic vessel or stillwell to maintain CE requirement.)

Mounting Affects: Twin Rod                   Active rod must be mounted at least 1" (25 mm) from any surface or obstruction. Minimum stillwell diameter for Twin Rod probe is 3" (76 mm).

Shock Class                                      ANSI/ISA-S71.03 Class SA1

Vibration Class                                  ANSI/ISA-S71.03 Class VC2

### 6.3.2 Performance - Model 705

Reference Conditions ①		Reflection from liquid of selected dielectric at +70° F (+20° C) (Model 705 with CFD threshold)
Linearity ②	Model 705:	<0.1% of probe length or 0.1 inch (whichever is greater)
Measured Error	Model 705:	±0.1% probe length or 0.1 inch (whichever is greater)
Resolution		±0.1 inch
Repeatability		<0.1 inch
Hysteresis		<0.1 inch
Response Time		<1 second
Warm-up Time		<5 seconds
Operating Temp. Range		-40° to +175° F (-40° to +80° C)
LCD Temp. Range		-5° to +160° F (-20° to +70° C)
Ambient Temp. Effect		Approximately +0.02% of probe length/ ° C
Process Dielectric Effect		<0.3 inch within selected range

① Specifications will degrade with Model 7XB, 7XD, and 7XP probes and/or Fixed threshold configuration.

② Top 24 inches of Model 7XB probe: 1.2 inches (30 mm). Specification for top 48 inches of single rod will be application dependent.

## 6.4 Model Numbers

### 6.4.1 Transmitter

#### BASIC MODEL NUMBER

705	Eclipse Guided Wave Radar Level Transmitter for use with probe models 7XA, 7XB, 7XD, 7XP, 7XR and 7XS only
-----	--

#### POWER

5	24 VDC, Two-wire
---	------------------

#### SIGNAL OUTPUT

2	Foundation Fieldbus Digital Communications (Model 705 only)
---	---

#### MENU LANGUAGE

1	English
---	---------

#### ACCESSORIES

0	No digital display and keypad (must be ordered with Signal Output Code 1)
A	Digital display and keypad

#### MOUNTING/CLASSIFICATION

1	Integral, General Purpose & Intrinsically Safe (FM & CSA), Non-incendive (Class I, Div. 2)
2	Remote, General Purpose & Intrinsically Safe (FM & CSA), Non-incendive (Class I, Div. 2)
3	Integral, Explosion Proof (FM & CSA)
4	Remote, Explosion Proof (FM & CSA)
A	Integral, General Purpose & Intrinsically Safe (ATEX & JIS EEx ia IIC T4)
B	Remote, General Purpose & Intrinsically Safe (ATEX & JIS EEx ia IIC T4)
C	Integral, Explosion Proof (ATEX EEx d ia IIC T4) (must be ordered with Conduit Connection Codes 0 and 1)
D	Remote, Explosion Proof (ATEX EEx d ia IIB T4) (must be ordered with Conduit Connection Codes 0 and 1)
E	Integral, Non-incendive (ATEX EEx n IIC T6) (Model 705 only)
F	Remote, Non-incendive (ATEX EEx n IIC T6) (Model 705 only)

#### HOUSING

1	Cast aluminum, dual compartment, 45° angle
2	316 stainless steel, dual compartment, 45° angle

#### CONDUIT CONNECTION

0	¾" NPT
1	M20
2	PG 13.5
3	PG 16

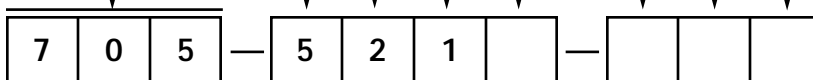

## 6.4.2 Probe

### BASIC MODEL NUMBER

7E	Eclipse GWR probe, English unit of measure
7M	Eclipse GWR probe, Metric unit of measure

### CONFIGURATION/STYLE

A	Coaxial, 3/4" process connection or larger	(Dielectric range ≥1.4)
B	Twin Rod, 2" NPT or 3" flanged process connection or larger	(Dielectric range ≥2.0)
D	Coaxial, High Temperature/High Pressure, 3/4" process conn. or larger	(Dielectric range ≥2.0)
P	Coaxial, High Pressure, 3/4" process connection or larger	(Dielectric range ≥1.7)
R	Coaxial, Overfill, 3/4" process connection or larger	(Dielectric range ≥1.4)
S	Coaxial, Hot Water/Steam, 3/4" process connection or larger	(Dielectric range ≥10)
5	Twin Rod, Flexible Bulk Solid, 2" process connection or larger	(Dielectric range ≥1.9)
7	Twin Rod Flexible, 2" NPT or 3" flanged process connection or larger	(Dielectric range 1.9–10)

### MATERIAL OF CONSTRUCTION

A	316/316L stainless steel
B	Hastelloy C, Configuration/Style codes A, B, F and R only
C	Monel, Configuration/Style codes A, B, F and R only
E	Sanitary, 316/316L stainless steel (20 Ra finish), Configuration/Style code F only, Process connections codes 4P, 5P, and 6P only
F	PFA faced flange, 2" to 4", 150# to 300#, Configuration/Style code F only, Process connection codes 43, 44, 53, 54, 63, 64, DA, DB, EA, EB, FA, and FB only
K	316/316L stainless steel probe and process connection, ASME B31.1 specifications (model 7XS only)
P	Paint Probe, 316/316L SS, 3/4" process connection or larger Configuration/Style code F only: maximum length 72"
4	PFA insulated rod, 2" NPT process connection or larger, Configuration/Style code F only

### PROCESS CONNECTION SIZE/TYPE

Refer to pages 42 and 43 for selections

### O-RINGS

0	Viton® GFLT
1	EPDM (Ethylene Propylene Rubber)
2	Kalrez 4079
8	Aegis PF128
N	None (Use with probes 7XD and 7XF-P)

### LENGTH – PROBE MODELS 7XA, 7XB, 7XD, 7XP, 7XR & 7XS

24" to 240" (60 cm to 610 cm) (7XS only: 180" (457 cm) maximum)  
(unit of measure is determined by second digit of Model Number)

Examples: 24 inches = 024; 60 centimeters = 060

### LENGTH – PROBE MODEL 7X7

3' to 20' (1 m to 6 m) – (7X7 only: 5' (1.5 m) minimum)  
(unit of measure is determined by second digit of Model Number)

Examples: 15 feet = 015; 10 meters = 010

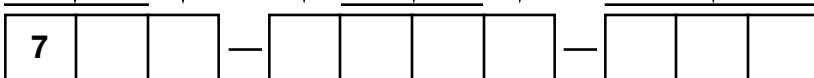

## 6.4.2 Probe

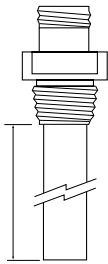

Insertion Length  
NPT Process Connection

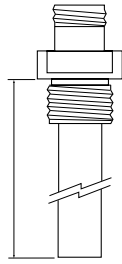

Insertion Length  
BSP Process Connection

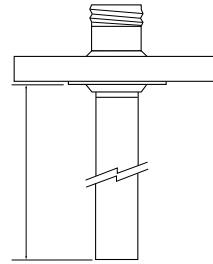

Insertion Length  
ANSI or DIN Welded Flange

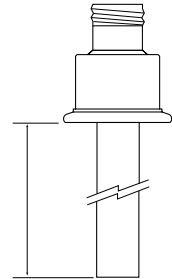

Insertion Length  
Sanitary Flange

### PROCESS CONNECTION SIZE/TYPE

#### THREADED CONNECTIONS

11	¾" NPT Thread ①
22	1" BSP Thread ①
41	2" NPT Thread ③
42	2" BSP Thread ③

#### ANSI RAISED FACE FLANGE CONNECTIONS

23	1" 150#	ANSI Raised Face Flange ①	48	2" 2500#	ANSI Raised Face Flange ②
24	1" 300#	ANSI Raised Face Flange ①	53	3" 150#	ANSI Raised Face Flange
25	1" 600#	ANSI Raised Face Flange ②	54	3" 300#	ANSI Raised Face Flange
27	1" 900/1500#	ANSI Raised Face Flange ②	55	3" 600#	ANSI Raised Face Flange ②
28	1" 2500#	ANSI Raised Face Flange ②	56	3" 900#	ANSI Raised Face Flange ②
33	1½" 150#	ANSI Raised Face Flange ①	57	3" 1500#	ANSI Raised Face Flange ②
34	1½" 300#	ANSI Raised Face Flange ①	58	3" 2500#	ANSI Raised Face Flange ②
35	1½" 600#	ANSI Raised Face Flange ②	63	4" 150#	ANSI Raised Face Flange
37	1½" 900/1500#	ANSI Raised Face Flange ②	64	4" 300#	ANSI Raised Face Flange
38	1½" 2500#	ANSI Raised Face Flange ②	65	4" 600#	ANSI Raised Face Flange ②
43	2" 150#	ANSI Raised Face Flange ①	66	4" 900#	ANSI Raised Face Flange ②
44	2" 300#	ANSI Raised Face Flange ①	67	4" 1500#	ANSI Raised Face Flange ②
45	2" 600#	ANSI Raised Face Flange ②	68	4" 2500#	ANSI Raised Face Flange ②
47	2" 900/1500#	ANSI Raised Face Flange ②			

#### ANSI RING JOINT FLANGE CONNECTIONS

3K	1½" 600#	ANSI Ring Joint Flange ②	5L	3" 900#	ANSI Ring Joint Flange ②
3M	1½" 900/1500#	ANSI Ring Joint Flange ②	5M	3" 1500#	ANSI Ring Joint Flange ②
3N	1½" 2500#	ANSI Ring Joint Flange ②	5N	3" 2500#	ANSI Ring Joint Flange ②
4K	2" 600#	ANSI Ring Joint Flange ②	6K	4" 600#	ANSI Ring Joint Flange ②
4M	2" 900/1500#	ANSI Ring Joint Flange ②	6L	4" 900#	ANSI Ring Joint Flange ②
4N	2" 2500#	ANSI Ring Joint Flange ②	6M	4" 1500#	ANSI Ring Joint Flange ②
5K	3" 600#	ANSI Ring Joint Flange ②	6N	4" 2500#	ANSI Ring Joint Flange ②

- ① Configuration/Style Codes A, D, P, R & S only.
- ② Configuration/Style Codes D & P only.
- ③ Configuration/Style Codes B, F, 1 & 7 only.



**PROPRIETARY AND SPECIALTY FLANGE CONNECTIONS**

4R	2" 150#	ANSI Raised Face Carbon Steel Flange with Top Hat
4S	2" 300/600#	ANSI Raised Face Carbon Steel Flange with Top Hat
5R	3" 150#	ANSI Raised Face Carbon Steel Flange with Top Hat
5S	3" 300/600#	ANSI Raised Face Carbon Steel Flange with Top Hat
TT	3½" 600#	Fisher® - Proprietary Carbon Steel (249B) Torque Tube Flange
TU	3½" 600#	Fisher - Proprietary 316 Stainless Steel (249C) Torque Tube Flange
UT	3½" 600#	Masoneilan® - Proprietary Carbon Steel Torque Tube Flange
UU	3½" 600#	Masoneilan - Proprietary 316 Stainless Steel Torque Tube Flange
UV	3½" 600#	Masoneilan - Proprietary Carbon Steel Torque Tube Flange with Top Hat
UW	3½" 600#	Masoneilan - Proprietary 316 Stainless Steel Steel Torque Tube Flange with Top Hat

**DIN FLANGE CONNECTIONS**

BA	DN 25, PN 16	DIN 2527 Form B Flange ①	DG	DN 50, PN 250	DIN 2527 Form E Flange ②
BB	DN 25, PN 25/40	DIN 2527 Form B Flange ①	DH	DN 50, PN 320	DIN 2527 Form E Flange ②
BC	DN 25, PN 64/100	DIN 2527 Form E Flange ②	DJ	DN 50, PN 400	DIN 2527 Form E Flange ②
BF	DN 25, PN 160	DIN 2527 Form E Flange ②	EA	DN 80, PN 16	DIN 2527 Form B Flange
BG	DN 25, PN 250	DIN 2527 Form E Flange ②	EB	DN 80, PN 25/40	DIN 2527 Form B Flange
BH	DN 25, PN 320	DIN 2527 Form E Flange ②	ED	DN 80, PN 64	DIN 2527 Form E Flange ②
BJ	DN 25, PN 400	DIN 2527 Form E Flange ②	EE	DN 80, PN 100	DIN 2527 Form E Flange ②
CA	DN 40, PN 16	DIN 2527 Form B Flange ①	EF	DN 80, PN 160	DIN 2527 Form E Flange ②
CB	DN 40, PN 25/40	DIN 2527 Form B Flange ①	EG	DN 80, PN 250	DIN 2527 Form E Flange ②
CC	DN 40, PN 64/100	DIN 2527 Form E Flange ②	EH	DN 80, PN 320	DIN 2527 Form E Flange ②
CF	DN 40, PN 160	DIN 2527 Form E Flange ②	EJ	DN 80, PN 400	DIN 2527 Form E Flange ②
CG	DN 40, PN 250	DIN 2527 Form E Flange ②	FA	DN 100, PN 16	DIN 2527 Form B Flange
CH	DN 40, PN 320	DIN 2527 Form E Flange ②	FB	DN 100, PN 25/40	DIN 2527 Form B Flange
CJ	DN 40, PN 400	DIN 2527 Form E Flange ②	FD	DN 100, PN 64	DIN 2527 Form E Flange ②
DA	DN 50, PN 16	DIN 2527 Form B Flange	FE	DN 100, PN 100	DIN 2527 Form E Flange ②
DB	DN 50, PN 25/40	DIN 2527 Form B Flange	FF	DN 100, PN 160	DIN 2527 Form E Flange ②
DD	DN 50, PN 64	DIN 2527 Form E Flange ②	FG	DN 100, PN 250	DIN 2527 Form E Flange ②
DE	DN 50, PN 100	DIN 2527 Form E Flange ②	FH	DN 100, PN 320	DIN 2527 Form E Flange ②
DF	DN 50, PN 160	DIN 2527 Form E Flange ②	FJ	DN 100, PN 400	DIN 2527 Form E Flange ②

① Configuration/Style Codes A, D, P, R & S only.  
 ② Configuration/Style Codes D & P only.

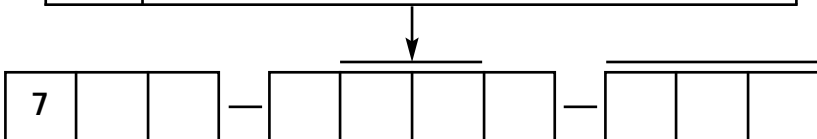

**6.5 References**

1. Foundation Fieldbus, A Pocket Guide  
Ian Verhappen, Augusto Pereira
2. Foundation Fieldbus—System Engineering Guidelines,  
AG-181



# 705FF Eclipse Guided Wave Radar Transmitter

## Configuration Data Sheet

Copy blank page and store calibration data for future reference and troubleshooting.

Item	Value	Value	Value		
Vessel Name					
Vessel #					
Media & Dielectric					
Tag #					
Electronics Serial #				<b>TROUBLESHOOTING</b>	
Probe Serial #				<b>Correct Value</b>	<b>Incorrect Value</b>
Level					
Probe Model					
Probe Mount					
Probe Length					
Offset					
Dielectric					
0% Set Point					
100% Set Point					
Fieldbus Address					
Fiducial Tick					
<Window>					
Range					
Gain					
Calibration Method					
Conversion Factor					
Scale Offset					
# of Ticks					
Threshold					
Software Version					
New Password					
<b>Name</b>					
<b>Date</b>					
<b>Time</b>					

### Service Policy

Owners of Magnetrol/STI controls may request the return of a control or any part of a control for complete rebuilding or replacement. They will be rebuilt or replaced promptly. Controls returned under our service policy must be returned by Prepaid transportation. Magnetrol/STI will repair or replace the control at no cost to the purchaser (or owner) other than transportation if:

1. Returned within the warranty period; and
2. The factory inspection finds the cause of the claim to be covered under the warranty.

If the trouble is the result of conditions beyond our control; or, is NOT covered by the warranty, there will be charges for labor and the parts required to rebuild or replace the equipment.

In some cases it may be expedient to ship replacement parts; or, in extreme cases a complete new control, to replace the original equipment before it is returned. If this is desired, notify the factory of both the model and serial numbers of the control to be replaced. In such cases, credit for the materials returned will be determined on the basis of the applicability of our warranty.

No claims for misapplication, labor, direct or consequential damage will be allowed.

### Return Material Procedure

So that we may efficiently process any materials that are returned, it is essential that a "Return Material Authorization" (RMA) number be obtained from the factory prior to the material's return. This is available through Magnetrol/STI's local representative or by contacting the factory. Please supply the following information:

1. Company Name
2. Description of Material
3. Serial Number
4. Reason for Return
5. Application

Any unit that was used in a process must be properly cleaned in accordance with OSHA standards, before it is returned to the factory.

A Material Safety Data Sheet (MSDS) must accompany material that was used in any media.

All shipments returned to the factory must be by prepaid transportation.

All replacements will be shipped F.O.B. factory.

Eclipse Guided Wave Radar transmitters may be protected by one or more of the following U.S. Patent Nos. US 6,062,095; US 6,247,362; US 6,588,272; US 6,626,038; US 6,640,629; US 6,642,807; US 6,690,320; US 6,750,808; US 6,801,157. May depend on model.



5300 Belmont Road • Downers Grove, Illinois 60515-4499 • 630-969-4000 • Fax 630-969-9489 • www.magnetrol.com  
145 Jardin Drive, Units 1 & 2 • Concord, Ontario Canada L4K 1X7 • 905-738-9600 • Fax 905-738-1306  
Heikensstraat 6 • B 9240 Zele, Belgium • 052 45.11.11 • Fax 052 45.09.93  
Regent Business Ctr., Jubilee Rd. • Burgess Hill, Sussex RH15 9TL U.K. • 01444-871313 • Fax 01444-871317



5300 Belmont Road • Downers Grove, Illinois 60515-4499 • 630-969-4028 • Fax 630-969-9489 • www.sticontrols.com

Copyright © 2005 Magnetrol International, Incorporated. All rights reserved. Printed in the USA.  
Magnetrol and Magnetrol logotype are registered trademarks of Magnetrol International.  
STI and STI logotype are registered trademarks of Magnetrol International.

Performance specifications are effective with date of issue and are subject to change without notice.  
The brand and product names contained within this document are trademarks or registered trademarks of their respective holders.  
Viton® is a registered trademark of DuPont Performance Elastomers.

**BULLETIN: 57-640.0**  
**EFFECTIVE: January 2005**