

### INSTRUCTION MANUAL AND REPLACEMENT PARTS

#### DESCRIPTION

Magnetrol side mounting controls mount horizontally to any tank or vessel through a threaded or flanged pipe connection. Standard models are normally equipped with a single switch mechanism for high or low level alarm or control applications. Tandem models with two switch mechanisms are available for two level stage applications, providing the operating functions of two separate instruments such as high and low level alarm.

#### OPERATING PRINCIPLE

Side mounting units employ permanent magnetic force as the only link between the float and the switching element. As the pivoted float follows, liquid level changes, it moves a magnetic sleeve ① into or out the field of a switch actuating magnet ② causing switch operation. A non-magnetic barrier tube ③ effectively isolates the switch mechanism from the controlled liquid.

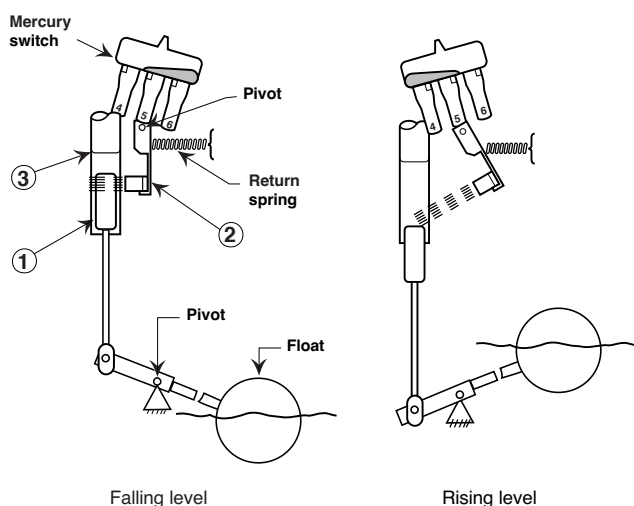

Figure 1

#### UNPACKING

Unpack the instrument carefully. Inspect all units for damage. Report any concealed damage to carrier within 24 hours. Check the contents of the packing slip and purchase order. Check and record the serial number for future reference when ordering parts.

#### AGENCY APPROVALS

Agency	Approval
ATEX	II 2G EEx d II C T6, explosion proof II 1G EEx ia II C T6, intrinsically safe
CCE ①	Explosion proof & intrinsically safe
FM	Class I, Div. 1, Groups C & D Class II, Div. 1, Groups E, F & G, Type NEMA 7/9
FM/CSA ②	Non-Hazardous area Explosion proof area – Groups B, C, D, E, F & G Type NEMA 4X/7/9
SAA ②	Explosion proof area
LRS	Lloyds Register of Shipment (marine applications)
GOST/ GOSGORTECHNADZOR ②	Russian Authorisation Standards
Other approvals are available, consult factory for more details	

① For CCE approved units, use the ATEX model numbers.  
② Consult factory for proper model numbers.

# MODEL IDENTIFICATION

## A complete measuring system consists of:

- Code for **side mounted** models (each unit can be factory calibrated when specific level differentials are specified separately).
- Code for **modified** models or adders: put an "X" in front of the closest matching order code and specify the modifications/adders separately  
eg. XT62-AG3A-AAP      X = with material certification EN 10204 / DIN 50049-3.1.B
- OPTION: External cage: consult factory for model description.

1. Code for T62/T67 side mounted float level switch

### BASIC MODEL NUMBER

#### – Single switch model

T	6	2	down to S.G. 0,50	up to 34,5 bar (500 psi)
---	---	---	-------------------	--------------------------

#### – Dual switch model

T	6	7	down to S.G. 0,50	up to 34,5 bar (500 psi)
---	---	---	-------------------	--------------------------

### MATERIALS OF CONSTRUCTION

Code	Cage & process connection material	Float and trim	Magnetic sleeve
A	Carbon steel	316 SST (1.4401)	400 series SST
B			316 SST (1.4401)
D	316/316L (1.4401/1.4404)		

### PROCESS CONNECTION

#### – threaded

F	2	3" NPT
---	---	--------

#### – ANSI flanges

G	3	3" 150 lbs ANSI RF
G	4	3" 300 lbs ANSI RF
H	3	4" 150 lbs ANSI RF
H	4	4" 300 lbs ANSI RF

#### – DIN flanges

7	F	DN 80, PN 16 DIN 2527 form C
7	G	DN 80, PN 25/40 DIN 2527 form C
8	F	DN 100, PN 16 DIN 2527 form C
8	G	DN 100, PN 25/40 DIN 2527 form C

### FLOAT AND STEM LENGTH

Stem length versus min S.G.					Float size mm (inches) <sup>①</sup>	Max pressure bar (psi)				
203 mm (8")	305 mm (12")	457 mm (18")	660 mm (26")	@ 40 °C (100 °F)		@ 400 °C (750 °F)				
A	0,80	B	0,80	C	0,90	D	0,90	∅ 64 (2.50)	24,1 (350)	13,8 (200)
E	0,52	F	0,55	G	0,60	H	0,66	∅ 64 x 102 (2.50 x 4.00)	6,9 (100)	4,1 (60)
J	0,55	K	0,55	L	0,60	M	0,60	∅ 76 (3.00)	17,2 (250)	10,3 (150)
N	0,50	P	0,50	Q	0,55	R	0,55	∅ 89 (3.50)	27,6 (400)	15,5 (225)
S	0,65	T	0,65	V	0,70	W	0,70	∅ 76 x 127 (3.00 x 5.00)	34,5 (500)	20,7 (300)

<sup>①</sup> All floats can be screwed to float stem from inside of vessel in case the float cannot pass through the nozzle.

### SWITCH MECHANISM & ENCLOSURE

- for T62 units (see page 3)
- for T67 units (see page 4)
- for pneumatic switch mechanisms (see table below)

T	6						
---	---	--	--	--	--	--	--

**complete code for T62/T67 side mounted float level switch**

### Select pneumatic switch mechanism & enclosure - for T62/T64 models

Pneumatic switch type	Max supply pressure bar (psi)	Max liquid temperature °C (°F)	Bleed orifice Ø mm (inches)	NEMA 3R (IP 53)	
				material code A	material codes B & D
Series J (open air)	6,9 (100)	200 (400)	1,60 (0.063)	JDE	JDE
	4,1 (60)	200 (400)	2,39 (0.094)	JEE	JEE
	4,1 (60)	370 (700)	1,40 (0.055)	JFE	JFE
Series K (closed circuit)	6,9 (100)	200 (400)	-	-	KOE
	2,8 (40)	200 (400)	-	KOG	-

1. Code for T64 side mounted float level switch

BASIC MODEL NUMBER

- Single switch model

T	6	4	down to S.G. 0,40 up to 82,7 bar (1200 psi)
---	---	---	---

MATERIALS OF CONSTRUCTION

Code	Cage & process connection material	Float and trim	Magnetic sleeve
A	Carbon steel	304 SST (1.4301) / 316 SST (1.4401)	400 series SST

PROCESS CONNECTION

- ANSI flanges

H 3	4" 150 lbs ANSI RF
H 4	4" 300 lbs ANSI RF
H 5	4" 600 lbs ANSI RF

- DIN flanges

8 F	DN 100, PN 16 DIN 2527 form C
8 G	DN 100, PN 25/40 DIN 2527 form C
8 H	DN 100, PN 64 DIN 2527 form E
8 J	DN 100, PN 100 DIN 2527 form E

FLOAT AND STEM LENGTH

N	Fixed stem length: 203 mm (8") Min. S.G: 0,40 Float size: ø 89 mm (3.50") Float rating: 82,7 bar (1200 psi) @ 40 °C (100 °F) 400 °C (750 °F) @ 51,7 bar (750 psi)
---	---

SWITCH MECHANISM & ENCLOSURE - for electric switch mechanisms (see table below)  
- for pneumatic switch mechanisms (see page 2)

T	6	4	A		N		
---	---	---	---	--	---	--	--

complete code for T64 side mounted float level switch

Select electric switch mechanism & enclosure for T62 and T64 models (see page 3 for switch ratings)

qty and switch type	All models with material code A										All models with material codes B and D									
	Weather proof (IP 66)		ATEX (IP 66)						FM (IP 66)		Weather proof (IP 66)		ATEX (IP 66)						FM (IP 66)	
			II 2G EEx d IIC T6		II 1G EEx ia II C T6		II 2G EEx d IIC T6		NEMA 7/9	II 2G EEx d IIC T6			II 1G EEx ia II C T6		II 2G EEx d IIC T6		NEMA 7/9			
	cast Aluminium	cast Aluminium	cast Aluminium	cast Aluminium	cast Iron	cast Alu.	cast Aluminium	cast Aluminium	cast Aluminium	cast Iron	cast Alu.	cast Aluminium	cast Aluminium	cast Aluminium	cast Iron	cast Alu.				
M20 x 1,5	1" NPT	M20 x 1,5	1" NPT	M20 x 1,5	1" NPT	M20 x 1,5	3/4" NPT	1" NPT	M20 x 1,5	1" NPT	M20 x 1,5	1" NPT	M20 x 1,5	1" NPT	M20 x 1,5	3/4" NPT	1" NPT			
A	1 x SPDT	A2P	AAP	AHC	AAC	-	-	AK7	AU7	AKP	A2Q	AAQ	AH9	AA9	-	-	AK5	AU5	AKQ	
	1 x DPDT	A8P	ADP	AJC	ABC	-	-	AD7	AW7	ANP	A8Q	ADQ	AJ9	AB9	-	-	AD5	AW5	ANQ	
3	1 x SPDT	32P	3AP	3HC	3AC	-	-	3K7	3U7	3KP	32Q	3AQ	3H9	3A9	-	-	3K5	3U5	3KQ	
	1 x DPDT	38P	3DP	3JC	3BC	-	-	3D7	3W7	3NP	38Q	3DQ	3J9	3B9	-	-	3D5	3W5	3NQ	
B	1 x SPDT	B2P	BAP	BHC	BAC	-	-	BK7	BU7	BKP	B2Q	BAQ	BH9	BA9	-	-	BK5	BU5	BKQ	
	1 x DPDT	B8P	BDP	BJC	BBC	-	-	BD7	BW7	BNP	B8Q	BDQ	BJ9	BB9	-	-	BD5	BW5	BNQ	
C	1 x SPDT	C2P	CAP	CHC	CAC	C2L	CAL	CK7	CU7	CKP	C2Q	CAQ	CH9	CA9	C2S	CAS	CK5	CU5	CKQ	
	1 x DPDT	C8P	CDP	CJC	CBC	C8L	CDL	CD7	CW7	CNP	C8Q	CDQ	CJ9	CB9	C8S	CDS	CD5	CW5	CNQ	
D	1 x SPDT	-	-	-	-	-	-	-	-	-	D2Q	DAQ	DH9	DA9	-	-	DK5	DU5	DKQ	
	1 x DPDT	-	-	-	-	-	-	-	-	-	D8Q	DDQ	DJ9	DB9	-	-	DD5	DW5	DNQ	
F	1 x SPDT	F2P	FAP	FHC	FAC	-	-	FK7	FU7	FKP	F2Q	FAQ	FH9	FA9	-	-	FK5	FU5	FKQ	
	1 x DPDT	F8P	FDP	FJC	FBC	-	-	FD7	FW7	FNP	F8Q	FDQ	FJ9	FB9	-	-	FD5	FW5	FNQ	
HS	1 x SPDT	-	-	-	-	-	-	-	-	-	H7A	HM2	HFC	HA9	-	-	HB3	HB4	HM3	
	1 x DPDT	-	-	-	-	-	-	-	-	-	H7C	HM6	HGC	HB9	-	-	HB7	HB8	HM7	
U	1 x SPDT	U2P	UAP	UHC	UAC	U2L	UAL	UK7	UU7	UKP	U2Q	UAQ	UH9	UA9	U2S	UAS	UK5	UU5	UKQ	
	1 x DPDT	U8P	UDP	UJC	UBC	U8L	UDL	UD7	UW7	UNP	U8Q	UDQ	UJ9	UB9	U8S	UDS	UD5	UW5	UNQ	
V	-	-	-	-	-	VFS	VHS	-	-	-	-	-	-	-	-	V5S	VBS	-	-	
W	1 x SPDT	W2P	WAP	WHC	WAC	W2L	WAL	WK7	WU7	WKP	W2Q	WAQ	WH9	WA9	W2S	WAS	WK5	WU5	WKQ	
	1 x DPDT	-	-	-	-	-	-	-	-	-	W8Q	WDQ	WJ9	WB9	W8S	WDS	WD5	WW5	WNQ	
X	1 x SPDT	X2P	XAP	XHC	XAC	X2L	XAL	XK7	XU7	XKP	X2Q	XAQ	XH9	XA9	X2S	XAS	XK5	XU5	XKQ	
	1 x DPDT	-	-	-	-	-	-	-	-	-	X8Q	XDQ	XJ9	XB9	X8S	XDS	XD5	XW5	XNQ	

Select electric switch mechanism & enclosure for **T67 models** (see page 3 for switch ratings)

qty and switch type	All models with material code A										All models with material codes B and D									
	Weather proof (IP 66)		ATEX (IP 66)						FM (IP 66)		Weather proof (IP 66)		ATEX (IP 66)						FM (IP 66)	
			II 2G EEx d II C T6		II 1G EEx ia II C T6		II 2G EEx d II C T6		NEMA 7/9	II 2G EEx d II C T6			II 1G EEx ia II C T6		II 2G EEx d II C T6		NEMA 7/9			
	cast Aluminium		cast Aluminium		cast Aluminium		cast Iron		cast Alu.	cast Aluminium		cast Aluminium		cast Aluminium		cast Iron		cast Alu.		
M20 x 1,5	1" NPT	M20 x 1,5	1" NPT	M20 x 1,5	1" NPT	M20 x 1,5	3/4" NPT	1" NPT	M20 x 1,5	1" NPT	M20 x 1,5	1" NPT	M20 x 1,5	1" NPT	M20 x 1,5	3/4" NPT	1" NPT			
A	2 x SPDT	A4A	ABA	ALC	ADC	-	-	AL7	AV7	ALA	A4B	ABB	AL9	AD9	-	-	AL5	AV5	ALB	
	2 x DPDT	A1A	AEA	APC	AGC	-	-	A07	AY7	AOA	A1B	AEB	AP9	AG9	-	-	A05	AY5	AOB	
3	2 x SPDT	34E	3BE	39E	3DE	-	-	3L7	3V7	3LE	34B	3BB	3L9	3D9	-	-	3L5	3V5	3LB	
	2 x DPDT	31A	3EA	3PC	3GC	-	-	307	3Y7	30A	31B	3EB	3P9	3G9	-	-	305	3Y5	30B	
B	2 x SPDT	B4A	BBA	BLC	BDC	-	-	BL7	BV7	BLA	B4B	BBB	BL9	BD9	-	-	BL5	BV5	BLB	
	2 x DPDT	B1A	BEA	BPC	BGC	-	-	B07	BY7	BOA	B1B	BEB	BP9	BG9	-	-	B05	BY5	BOB	
C	2 x SPDT	C4A	CBA	CLC	CDC	C4X	CBX	CL7	CV7	CLA	C4B	CBB	CL9	CD9	C4T	CBT	CL5	CV5	CLB	
	2 x DPDT	C1A	CEA	CPC	CGC	C1X	CEX	C07	CY7	COA	C1B	CEB	CP9	CG9	C1T	CET	C05	CY5	COB	
D	2 x SPDT	D4B	DBB	DL9	DD9	-	-	DL5	DV5	DLB	D4B	DBB	DL9	DD9	-	-	DL5	DV5	DLB	
	2 x DPDT	D1B	DEB	DP9	DG9	-	-	D05	DY5	DOB	D1B	DEB	DP9	DG9	-	-	D05	DY5	DOB	
F	2 x SPDT	FFA	FBA	FLC	FDC	-	-	FL7	FV7	FLA	FFB	FBB	FL9	FD9	-	-	FL5	FV5	FLB	
	2 x DPDT	FHA	FEA	FPC	FGC	-	-	F07	FY7	FOA	FHB	FEB	FP9	FG9	-	-	F05	FY5	FOB	
U	2 x SPDT	U4A	UBA	ULC	UDC	U4X	UBX	UL7	UV7	ULA	U4B	UBB	UL9	UD9	U4T	UBT	UL5	UV5	ULB	
	2 x DPDT	U1A	UEA	UPC	UGC	U1X	UEX	U07	UY7	UOA	U1B	UEB	UP9	UG9	U1T	UET	U05	UY5	UOB	
W	2 x SPDT	W4A	WBA	WLC	WDC	W4X	WBX	WL7	WV7	WLA	W4B	WBB	WL9	WD9	W4T	WBT	WL5	WV5	WLB	
	2 x DPDT	W1B	WEB	WP9	WG9	W1T	WET	W05	WY5	WOB	W1B	WEB	WP9	WG9	W1T	WET	W05	WY5	WOB	
X	2 x SPDT	X4A	XBA	XLC	XDC	X4X	XBX	XL7	XV7	XLA	X4B	XBB	XL9	XD9	X4T	XBT	XL5	XV5	XLB	
	2 x DPDT	X1B	XEB	XP9	XG9	X1T	XET	X05	XY5	XOB	X1B	XEB	XP9	XG9	X1T	XET	X05	XY5	XOB	

# INSTALLATION

## MOUNTING

Before assembling control to tank or vessel, check threaded or flanged mounting nozzle for the following:

- Nozzle length and inside diameter must be sized correctly to allow for switch actuation at design levels within the maximum differential available (see table on page 4).
- Nozzle should be checked for horizontal alignment. Finished mounting must allow control switch housing to be within 3° degrees of vertical for proper operation. A three degree slant is noticeable by eye, but installation should be checked with a spirit level.

## WIRING

Most mechanical control switch housings are designed to allow 360° positioning of the cable entries by loosening the set screw(s). See **figure 2**. On high temperature applications (above 120° C [250° F]), high temperature wire should be used between control and first junction box located in a cooler area.

1. To gain access to switch mechanism(s) remove switch housing cover.
2. Pull in supply wires (conductors), wrap them around enclosing tube under the baffle plate and connect to proper terminals. Be certain that excess wire does not interfere with "tilt" of switch and that adequate clearance exists for replacement of switch housing cover.

**NOTE:** See bulletin on switch mechanism furnished with your control (as listed below) for proper connections.

3. Connect power supply to control and test switch action by varying liquid level in tank or vessel.

**NOTE:** If switch mechanism fails to function properly, check vertical alignment of control housing and consult installation instructions in switch mechanism bulletin.

4. Replace switch housing cover and place control into service.

**NOTE:** If control has been furnished with an explosion proof (cast) or moisture proof (gasketed) switch housing, check the following:

- After wiring connections have been completed, housings must be sealed via the correct cable gland to prevent entrance of air.
- Check cover to base fit, to be certain gasketed joint is tight. A positive seal is necessary to prevent infiltration of moisture laden air or corrosive gases into switch housing.

**CAUTION:**

In hazardous area, do not power the unit until the cable gland is sealed and the enclosure cover is screwed down securely.

Switch mechanism	Bulletin	Reference series
Mercury switches	42-783	A
Dry contact switches	42-683	B, C, D, U, W, X
Anti-vibration mercury switches		E
Anti-vibration dry contact switches	42-684	G, H, I
Bleed type pneumatic valve	42-685	J
Non-bleed type pneumatic valve	42-686	K

OBSERVE ALL APPLICABLE ELECTRICAL CODES AND PROPER WIRING PROCEDURES

NEMA 4x

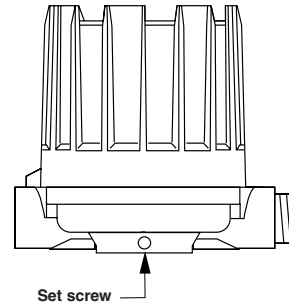

NEMA 7/9

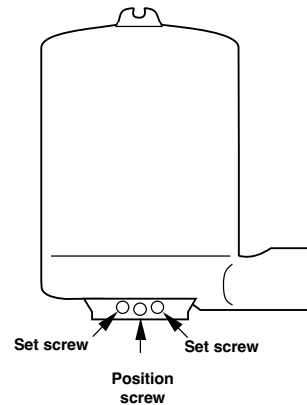

ATEX

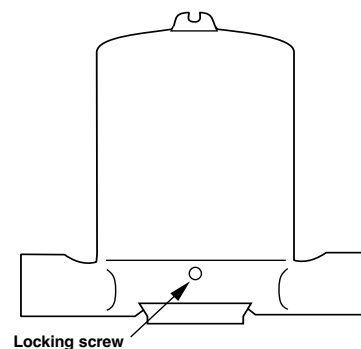

Figure 2

**CAUTION:**

- DO NOT attempt to reposition NEMA 4 / NEMA 7/9 housings without loosening the set screws; ATEX housings MAY NOT BE REPOSITIONNED. ALWAYS retighten set screw(s) after repositioning.
- DO NOT attempt to unscrew cover of ATEX housings before loosening locking screw in base of housing. ALWAYS retighten locking screw after replacing cover.

# LEVEL DIFFERENTIAL ADJUSTMENT

The level differential setting of the side mounting controls can be field adjusted within limits specified in the table at right by repositioning the jam nuts on the magnetic sleeve stem.

**NOTE:** The control need not be removed from tank or vessel to make differential adjustment.

**CAUTION:** Before attempting any work on the control, be certain to pull disconnect switch or otherwise assure that electrical circuit(s) through control is deactivated. Close operating medium supply valve on controls equipped with pneumatic switch mechanisms.

1. Disconnect wiring from supply side of switch mechanism and electrical conduit or operating medium line connections to switch housing.
2. Perform system shut-down as required to relieve pressure from tank or vessel and drain off liquid "head" above control mounting position. Allow unit to cool.
3. Remove switch housing assembly by loosening hex nut located immediately below housing base.

With switch housing removed, jam nuts and magnetic sleeve are now accessible, as in **Figure 3**. Raising the lower jam nuts or lowering the upper jam nuts will reduce the differential. Jam nut adjustments in opposite directions will, of course, increase the differential. As the first step in any adjustment procedure, the position of the lower jam nuts (dimension A) should be established.

4. Loosen and remove upper jam nuts, guide washer and magnetic sleeve. Dimension "A", as measured from top of stem to top of lower jam nuts, may now be increased or decreased as desired.

Tandem model units have two switch mechanisms actuated by two independent magnetic sleeves. For adjustment purposes, each sleeve and jam nut set is considered as an individual unit in conjunction with the switch mechanism it operates.

**NOTE:** Be certain to tighten jam nuts securely after adjustment.

5. Replace magnetic sleeve on stem and position upper jam nuts to desired "B" dimension by measuring from top of sleeve to bottom of upper jam nuts. Lock upper jam nuts to guide washer.
6. Reassemble control in reverse of steps 1 through 3, previously described.
7. Test switch actuation by varying liquid level in tank or vessel.

**CAUTION:** After increasing differential adjustment, be certain to check carefully for proper operation of switch mechanism. Magnet must "snap" cleanly with additional float movement available after magnet snaps.

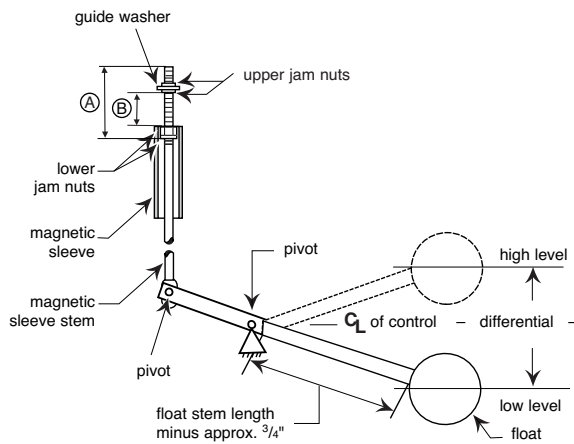

Figure 3

## Millimeters

Model ①	Differentials Obtainable ② ④				Approx. Jam Nut Setting ③		
		Float Stem Length				A	B
		203	305	457	660		
T62 (Threaded)	Min.	32	51	73	102	21	0.8
	Max.	148	206	294	409	33	27
T62 (Flanged)	Min.	32	41	67	95	16	0.8
	Max.	89	130	191	273	28	18

## Inches

Model ①	Differentials Obtainable ② ④				Approx. Jam Nut Setting ③		
		Float Stem Length				A	B
		8.00	12.00	18.00	26.00		
T62 (Threaded)	Min.	1.25	2.00	2.88	4.00	0.81	0.03
	Max.	5.81	8.12	11.56	16.12	1.31	1.06
T62 (Flanged)	Min.	1.25	1.62	2.62	3.75	0.62	0.03
	Max.	3.50	5.12	7.50	10.75	1.12	0.69

## Notes:

- ① All models are factory set at minimum differential unless otherwise specified.
- ② To maintain maximum differential, nozzle length "L" (**Fig. 2**) must not exceed: 64 mm (2.50") model T62 threaded; or 89 mm (3.50") model T62 flanged.
- ③ Dimensions given are approximate and will vary slightly with each unit.
- ④ Consult factory for differentials of models not shown.

# LEVEL DIFFERENTIAL ADJUSTMENT (cont.)

## LEVEL DIFFERENTIAL VS. MOUNTING NOZZLE LENGTH

The tables below may be used to determine the maximum level travel (differential) available between "Switch on" and "Switch off" actuations with mounting nozzles of different lengths. The differentials given occur with the minimum tank opening diameter listed for each model and are applicable to standard controls.

### Level differential in mm (inches)

Models	dim. "D"	Differential	dim. "L"	Float stem length versus level differential			
				203 mm (8")	305 mm (12")	457 mm (18")	660 mm (26")
T62 threaded	77,9 mm (3.07") 3" – Sch 40	min	Not applicable	32 (1.26)	51 (2.01)	73 (2.87)	102 (4.02)
		max	50 mm (2")	148 (5.83)	206 (8.11)	294 (11.58)	409 (16.10)
			100 mm (4")	111 (4.37)	155 (6.10)	221 (8.70)	310 (12.20)
			150 mm (6")	38 (1.50)	119 (4.69)	170 (6.69)	236 (9.29)
			200 mm (8")	-	97 (3.82)	138 (5.43)	192 (7.56)
			250 mm (10")	-	81 (3.19)	116 (4.57)	162 (6.38)
			305 mm (12")	-	-	100 (3.94)	138 (5.43)
T62 flanged	73,7 mm (2.90") 3" – Sch 80	min	Not applicable	32 (1.26)	41 (1.61)	67 (2.64)	95 (3.74)
		max	50 mm (2")	89 (3.50)	130 (5.12)	191 (7.52)	273 (10.75)
			100 mm (4")	83 (3.27)	121 (4.76)	178 (7.01)	254 (10.00)
			150 mm (6")	-	95 (3.74)	137 (5.39)	197 (7.76)
			200 mm (8")	-	76 (2.99)	114 (4.49)	159 (6.26)
			250 mm (10")	-	64 (2.52)	95 (3.74)	137 (5.39)
			305 mm (12")	-	-	83 (3.27)	117 (4.61)
T64 flanged	102,3 mm (4.03") 4" – Sch 40	fixed	max 178 mm (7")	32 (1.26)	Not applicable	Not applicable	Not applicable
T67 threaded	77,9 mm (3.07") 3" – Sch 40	min	max 57 mm (2.25")	25 (1.00)	38 (1.50)	54 (2.12)	76 (3.00)
		max		64 (2.50)	95 (3.75)	140 (5.50)	197 (7.75)
T67 flanged	73,7 mm (2.90") 3" – Sch 80	min	max 89 mm (3.50")	25 (1.00)	38 (1.50)	54 (2.12)	76 (3.00)
		max		48 (1.88)	68 (2.69)	99 (3.88)	140 (5.50)

All units are factory set at minimum differential unless otherwise specified. Consult factory for differentials not shown.

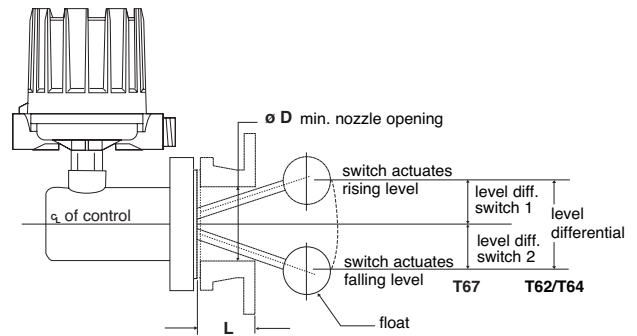
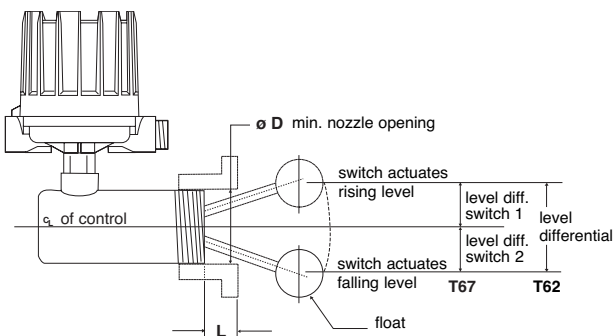

# PREVENTIVE MAINTENANCE

Periodic inspections are a necessary means to keep your Magnetrol level control in good working order. This control is, in reality, a safety device to protect the valuable equipment it serves. Therefore, a systematic program of "preventive maintenance" should be implemented when control is placed into service. If the following sections on "what to do" and "what to avoid" are observed, your control will provide reliable protection of your capital equipment for many years.

## WHAT TO DO

### 1. Keep control clean

**NEVER** leave switch housing cover off the control. This cover is designed to keep dust and dirt from interfering with switch mechanism operation. In addition, it protects against damaging moisture and acts as a safety feature by keeping bare wires and terminals from being exposed. Should the housing cover become damaged or misplaced, order a replacement immediately.

### 2. Inspect switch mechanisms, terminals and connections monthly.

- Mercury switches may be visually inspected for short circuit damage. Check for small cracks in the glass tube containing the mercury. Such cracks can allow entrance of air into the tube causing the mercury to "oxidize". This is noticeable as the mercury will appear dirty and have a tendency to "string out" like water, instead of breaking into round pools. If these conditions exist, replace the mercury switch immediately.
- Dry contact switches should be inspected for excessive wear on actuating lever or misalignment of adjusting screw at point of contact between screw and lever. Such wear can cause false switch actuating levels. Adjust switch mechanism to compensate (if possible) or replace switch.

Do **NOT** operate your control with defective or maladjusted switch mechanisms (refer to bulletin on switch mechanism furnished for service instructions).

- Magnetrol controls may sometimes be exposed to excessive heat or moisture. Under such conditions, insulation on electrical wires may become brittle, eventually breaking or peeling away. The resulting "bare" wires can cause short circuits.

Check wiring carefully and replace at first sign of brittle insulation.

- Vibration may sometimes cause terminal screws to work loose. Check all terminal connections to be certain that screws are tight. Air (or gas) operating medium lines subjected to vibration may eventually crack or become loose at connections causing leakage. Check lines and connections carefully and repair or replace, if necessary.
- On units with pneumatic switches, air (or gas) operating medium lines subjected to vibration, may eventually crack or become loose at connections carefully and repair or replace, if necessary.

**NOTE:** As a matter of good practice, spare switches should be kept on hand at all times.

### 3. Inspect entire unit periodically

Isolate control from vessel. Raise and lower liquid level to check for switch contact and reset.

## WHAT TO AVOID

1. **NEVER** leave switch housing cover off the control longer than necessary to make routine inspections.
2. **NEVER** use lubricants on pivots of switch mechanisms. A sufficient amount of lubricant has been applied at the factory to insure a lifetime of service. Further oiling is unnecessary and will only tend to attract dust and dirt which can interfere with mechanism operation.
3. **NEVER** place a jumper wire across terminals to "cut-out" the control. If a "jumper" is necessary for test purposes, be certain it is removed before placing control into service.
4. **NEVER** attempt to make adjustments or replace switches without reading instructions carefully. Certain adjustments provided for in Magnetrol controls should not be attempted in the field. When in doubt, consult the factory or your local Magnetrol representative.

# TROUBLE SHOOTING

Usually the first indication of improper operation is failure of the controlled equipment to function, i.e.: pump will not start (or stop), signal lamps fail to light, etc. When these symptoms occur, whether at time of installation or during routine service thereafter, check the following potential external causes first.

- Fuses may be blown.
- Reset button(s) may need resetting.
- Power switch may be open.
- Controlled equipment may be faulty.
- Wiring leading to control may be defective.

If a thorough inspection of these possible conditions fails to locate the trouble, proceed next to a check of the control's switch mechanism.

## CHECK SWITCH MECHANISM

1. Pull disconnect switch or otherwise disconnect power to the control.
2. Remove switch housing cover.
3. Disconnect power wiring from switch assembly.
4. Swing magnet assembly in and out by hand to check carefully for any sign of binding. Assembly should require minimal force to move it through its full swing.
5. If binding exists, magnet may be rubbing enclosing tube. If magnet is rubbing, loosen magnet clamp screw and shift magnet position. Retighten magnet clamp screw.
6. If switch magnet assembly swings freely and mechanism still fails to actuate, check installation of control to be certain it is within the specified three (3°) degrees of vertical (Use spirit level on side of enclosing tube in two place, 90° apart).
7. If mechanism is equipped with a mercury switch, examine glass mercury tube closely as previously described in "Preventive Maintenance" section. If switch is damaged, replace it immediately.
8. If switch mechanism is operating satisfactorily, proceed to check sensing unit.

## CHECK SENSING UNIT

1. Re-connect power supply and carefully actuate switch mechanism manually (using a non-conductive tool) to determine whether controlled equipment will operate.

### CAUTION:

With electrical power "on", care should be taken to avoid contact with switch leads and connections at terminal block.

2. If controlled equipment responds to manual actuation test, trouble may be located in the level sensing portion of the control (float, stem and magnetic attraction sleeve[s]).

**NOTE:** Check first to be certain liquid is entering storage tank or vessel. A valve may be closed or pipe line plugged.

3. With liquid in tank or vessel, proceed to check level sensing action by removing switch housing assembly.
4. Inspect magnetic attraction sleeve(s) and inside of enclosing tube for excessive corrosion or solids build-up which could restrict movement, preventing sleeve(s) from reaching field of magnet(s).
5. If differential has been changed in the field, check tightness and position of the jam nuts.

**NOTE:** Differential adjustment affects a change in the amount of level travel between "switch on" and "switch off" actuations. Do **NOT** attempt adjustment without first consulting factory for assistance in computing level differential change for your control.

6. Check float to be certain it is buoyant in the liquid (tank or vessel must have adequate liquid level). If float is determined to be filled with liquid or collapsed, it must be replaced immediately. Do **NOT** attempt to repair a float.

If all the components in the control are in operating condition, the trouble must be (and should be) located external to the control. Repeat inspection of external conditions previously described.

**NOTE:** When in doubt about the condition or performance of a Magnetrol control, return it to the factory. See "Our Service Policy" on back page.

# DIMENSIONAL SPECIFICATIONS in mm (inches)

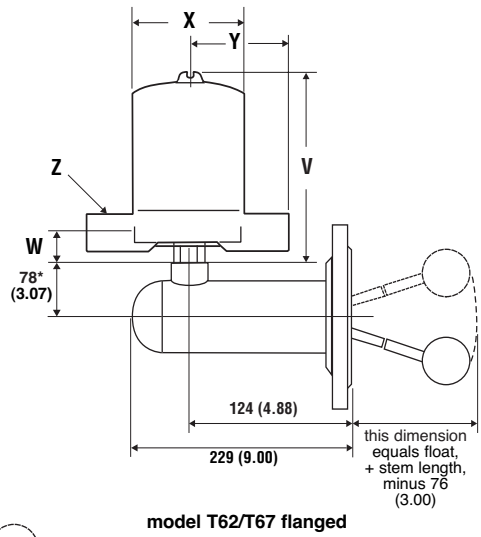
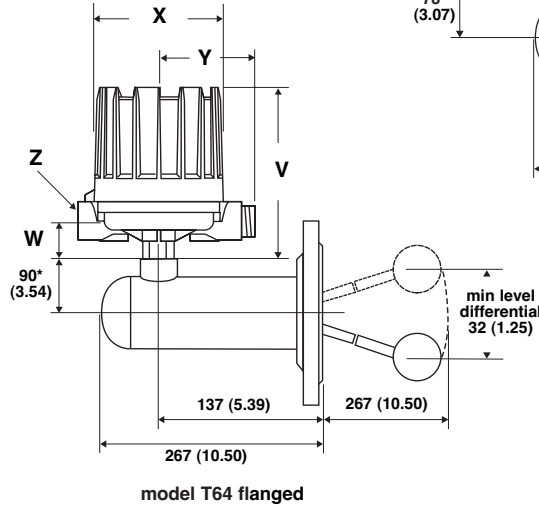
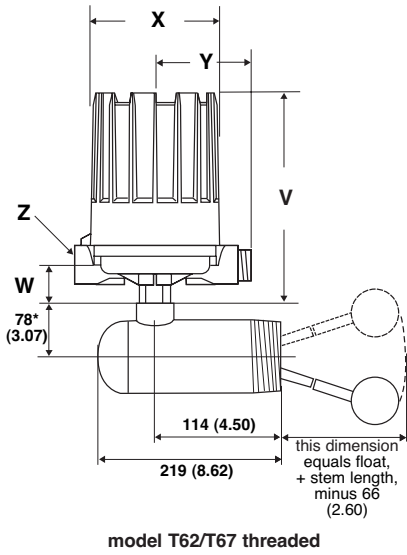

\* Dimensions for all housings, except for cast iron housing, add for these 76 mm (3")

Housing type	Models	V		W		Ø X		Y		Z
		mm	inches	mm	inches	mm	inches	mm	inches	
Weatherproof-FM (NEMA 7/9) - ATEX (Cast Alu)	T62/T64 with HS-switch and T67	257	10.12	42	1.66	151	5.93	109	4.29	M20 x 1,5 (*) or 1" NPT (2 entries - 1 plugged) (*) not for FM (NEMA 7/9)
	T62/T64 excl. HS-switch	202	7.94							
ATEX (Cast Iron)	All	249	9.80	45	1.77	143	5.63	110	4.33	M20 x 1,5 or 3/4" NPT (single entry - 2 entries at request)
Pneumatics Switch Module J	T62/T64	165	6.50	39	1.54	118	4.65	110	4.33	1/4" NPT
Pneumatics Switch Module K								130	5.12	

Allow 200 mm (7.87") overhead clearance / All housings are 360 ° rotatable

## REPLACEMENT PARTS

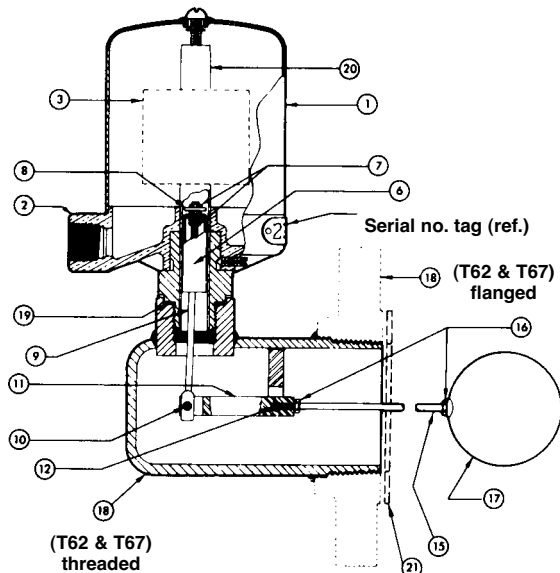
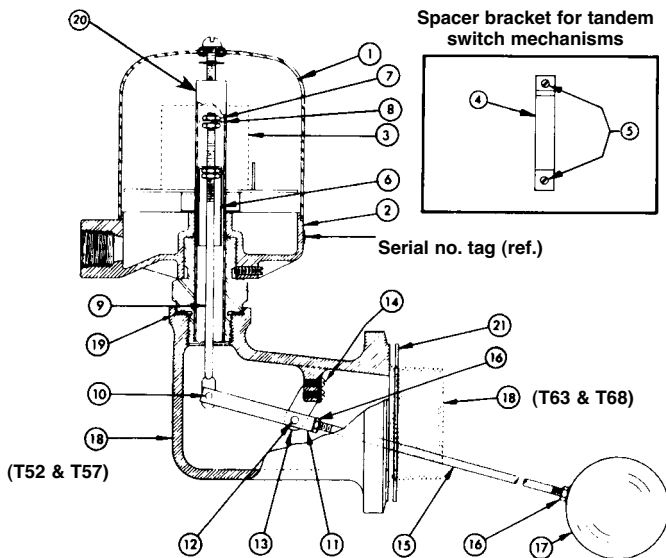

# REPLACEMENT PARTS

Item	Description		Replacement assemblies ①					
			Model					
			T62 threaded	T62 flanged	T64	T67 threaded	T67 flanged	
1	Switch housing cover	Housing kits	See bulletin BE 42-680/BE 42-780 ref. A, B, C, D & E switch housings replacement assemblies. Consult factory on series G, H, I, J & K.					
2	Switch housing base							
3	Switch mechanism(s)	—	See bulletin on switch mechanism(s) furnished, as listed below.					
4	Spacer bracket	—	N/R		—	05-7542-121		
5	Round head screws (2)	—				10-1409-006		
6	Attraction sleeve(s)	Stem kits ② Kits shown contain 203 mm (8.08") stem lengths. Consult factory for longer stem lengths.	89-5510-001 Standard sleeve  89-5514-001 Sheathed sleeve ④		—	89-5512-001 Standard sleeve	89-5511-001 Standard sleeve	
7	Jam nuts							
8	Guide washer							
9	Sleeve stem							
10	Connecting pin							
11	Fulcrum							
12	Fulcrum pin							
13	Pivot bracket							
14	Round head mach. screws							
15	Float stem							
16	Stem lock nuts							
17	Float ⑥	ø 64 (2,5")	89-5546-001		—	89-5546-001		
		ø 64 x 102 (2,5" x 4")	89-5553-001			89-5553-001		
		ø 76 (3")	89-5551-001			89-5551-001		
		ø 89 (3,5")	89-5552-001			07-1101-012	89-5552-001	
		ø 76 x 127 (3" x 5")	89-5554-001			89-5554-001		
		ø 76 x 152 (3" x 6")	89-5555-001			89-5555-001		
18	Body	—	33-6120-001	33-6124-001	—	33-6120-001	33-6124-001	
19	E-tube gasket	—	12-1301-002 ⑤					
20	Enclosing tube	Materiel code 1,2	NEMA 4 NEMA 7/9 Pneumatic housing	32-6302-031		32-6302-033		
			ATEX	32-6344-002				
		Materiel code 4	NEMA 4 NEMA 7/9 Pneumatic housing	32-6302-036		32-6302-037		
			ATEX	32-6344-001				
21	Flange gasket	—	N/R	N/A ③		N/R	N/A ③	

**N/R** = not required – **N/A** = not available

- ① All replacement assemblies listed are for standard base models which use Ref. series A, B, C, D, E and J switch mechanisms only. Consult local representative for ordering assistance on all special model replacement parts not included in the above listing.
- ② Sheathed attraction sleeves are used on models specified for corrosive service. Standard sleeve is type 400 series stainless steel.
- ③ Flange gasket used on T62, T64 and T67 units is standard ANSI type, readily available at local supply houses.
- ④ Sheathed sleeve stem kits are used on models with Material of Construction Codes 2 through 9.
- ⑤ Above 300 Lb. rating, use 12-1204-001.
- ⑥ Dimensions in millimeters (inches).

**IMPORTANT:**

**When ordering, please specify:**

**A. Model and serial number of control.**

**B. Name and number of replacement assembly.**

# IMPORTANT

## SERVICE POLICY

Owners of Magnetrol products may request the return of a control; or, any part of a control for complete rebuilding or replacement. They will be rebuilt or replaced promptly. Magnetrol International will repair or replace the control, at no cost to the purchaser, (or owner) **other than transportation cost** if:

- a. Returned within the warranty period; and,
- b. The factory inspection finds the cause of the malfunction to be defective material or workmanship.

If the trouble is the result of conditions beyond our control; or, is **NOT** covered by the warranty, there will be charges for labour and the parts required to rebuild or replace the equipment.

In some cases, it may be expedient to ship replacement parts; or, in extreme cases a complete new control, to replace the original equipment before it is returned. If this is desired, notify the factory of both the model and serial numbers of the control to be replaced. In such cases, credit for the materials returned, will be determined on the basis of the applicability of our warranty.

No claims for misapplication, labour, direct or consequential damage will be allowed.

## RETURNED MATERIAL PROCEDURE

So that we may efficiently process any materials that are returned, it is essential that a "Return Material Authorisation" (RMA) form will be obtained from the factory. It is mandatory that this form will be attached to each material returned. This form is available through Magnetrol's local representative or by contacting the factory. Please supply the following information:

1. Purchaser Name
2. Description of Material
3. Serial Number
4. Desired Action
5. Reason for Return
6. Process details

All shipments returned to the factory must be by prepaid transportation. Magnetrol **will not accept** collect shipments.

All replacements will be shipped FOB factory.

BULLETIN N°: BE 44-602.12  
EFFECTIVE: JANUARY 2005  
SUPERSEDES: December 1996

UNDER RESERVE OF MODIFICATIONS



www.magnetrol.com

BENELUX	Heikensstraat 6, 9240 Zele, België Tel. +32 (0)52.45.11.11 • Fax. +32 (0)52.45.09.93 • E-Mail: info@magnetrol.be
DEUTSCHLAND	Alte Ziegelei 2-4, D-51491 Overath Tel. 02204 / 9536-0 • Fax. 02204 / 9536-53 • E-Mail: vertrieb@magnetrol.de
FRANCE	40 - 42, rue Gabriel Péri, 95130 Le Plessis Bouchard Tél. 01.34.44.26.10 • Fax. 01.34.44.26.06 • E-Mail: magnetrolfrance@magnetrol.fr
ITALIA	Via Arese 12, I-20159 Milano Tel. (02) 607.22.98 (R.A.) • Fax. (02) 668.66.52 • E-Mail: mit.gen@magnetrol.it
UNITED KINGDOM	Unit 1 Regent Business Centre, Jubilee Road Burgess Hill West Sussex RH 15 9TL Tel. (01444) 871313 • Fax (01444) 871317 • E-Mail: sales@magnetrol.co.uk
INDIA	E-22, Anand Niketan, New Delhi - 110 021 Tel. 91 (11) 6186211 • Fax 91 (11) 6186418 • E-Mail: info@magnetrolindia.com